

# PLAN OF SUBDIVISION

**EDITION**

**PS 905616P**

**LOCATION OF LAND**

**PARISH:** KALKALLO  
**TOWNSHIP:** -  
**SECTION:** -  
**CROWN ALLOTMENT:** -  
**CROWN PORTION:** 26 (PART)  
**TITLE REFERENCE:** VOL FOL

**LAST PLAN REFERENCE:** LOT Y ON PS905624Q  
 LOT D ON PS905702W

**POSTAL ADDRESS:** (at time of subdivision) TITANIUM STREET  
 KALKALLO 3064

**MGA 94 CO-ORDINATES:** (approx. centre of land in plan) E 319 400 N 5 845 950 **ZONE:** 55

Council Name: Hume City Council  
 SPEAR Reference Number: S200025E

**VESTING OF ROADS AND/OR RESERVES**

**NOTATIONS**

IDENTIFIER	COUNCIL/BODY/PERSON	STAGING
ROAD R1 RESERVE No.1	HUME CITY COUNCIL AUSNET ELECTRICITY SERVICES PTY LTD	<b>THIS IS NOT A STAGED SUBDIVISION</b> PLANNING PERMIT NO. P20695
		<b>SURVEY</b> <b>THIS PLAN IS / IS NOT BASED ON SURVEY</b> THIS SURVEY HAS BEEN CONNECTED TO PERMANENT MARKS NO(S) MERRIANG 20 & 29 KALKALLO 72 IN PROCLAIMED SURVEY AREA NO. 74
		<b>DEPTH LIMITATION</b> DOES NOT APPLY
		LOTS 1 TO 32800 (BOTH INCLUSIVE) HAVE BEEN OMITTED FROM THIS PLAN. EASEMENTS E-4, E-7, E-9, E-11 & E-13 TO E-16 (BOTH INCLUSIVE) HAVE BEEN OMITTED FROM THIS PLAN. AREA OF LAND SUBDIVIDED IS 4.542ha.

**EASEMENT INFORMATION**

**LEGEND:** E - ENCUMBERING EASEMENT, CONDITION IN CROWN GRANT IN THE NATURE OF AN EASEMENT OR OTHER ENCUMBRANCE A - APPURTENANT EASEMENT  
 \*SUPPORT IS DEFINED AS ALL NECESSARY STRUCTURAL SUPPORT RIGHTS FOR RETAINING WALL PURPOSES

SUBJECT LAND	PURPOSE	WIDTH (metres)	ORIGIN	LAND BENEFITED/IN FAVOUR OF
E-1	DRAINAGE	SEE DIAG	THIS PLAN	HUME CITY COUNCIL
E-2	SEWERAGE	SEE DIAG	THIS PLAN	YARRA VALLEY WATER CORPORATION
E-3 E-3	DRAINAGE SEWERAGE	SEE DIAG SEE DIAG	THIS PLAN THIS PLAN	HUME CITY COUNCIL YARRA VALLEY WATER CORPORATION
E-5	*SUPPORT	0.50	THIS PLAN	THE RELEVANT ABUTTING LOTS ON THIS PLAN
E-6 E-6	*SUPPORT DRAINAGE	0.50 0.50	THIS PLAN THIS PLAN	THE RELEVANT ABUTTING LOTS ON THIS PLAN HUME CITY COUNCIL
E-8 E-8 E-8	*SUPPORT DRAINAGE SEWERAGE	0.50 0.50 0.50	THIS PLAN THIS PLAN THIS PLAN	THE RELEVANT ABUTTING LOTS ON THIS PLAN HUME CITY COUNCIL YARRA VALLEY WATER CORPORATION
E-10	*SUPPORT	0.50	THIS PLAN	VOL FOL (LOT H ON PS905702W)
E-12 E-12	*SUPPORT SEWERAGE	0.50 0.50	THIS PLAN THIS PLAN	VOL FOL (LOT H ON PS905702W) YARRA VALLEY WATER CORPORATION
E-17 E-17 E-17	*SUPPORT DRAINAGE SEWERAGE	0.50 0.50 0.50	THIS PLAN THIS PLAN THIS PLAN	VOL FOL (LOT E ON PS905702W) HUME CITY COUNCIL YARRA VALLEY WATER CORPORATION
E-18	*SUPPORT	0.50	SECTION 98 TLA 1958 PS905608N	THE RELEVANT ABUTTING LOTS ON PS905608N
A-1	*SUPPORT	0.50	SECTION 98 TLA 1958 THIS PLAN	THE RELEVANT ABUTTING LOTS ON THIS PLAN
A-2	*SUPPORT	0.50	PS905608N	THE RELEVANT ABUTTING LOTS ON THIS PLAN

 <p><b>VERIS AUSTRALIA PTY LTD</b>                  A   Level 3, 1 Southbank Blvd                  Southbank VIC 3006                  T   +61 3 7019 8400                  E   melbourne@veris.com.au                  W   www.veris.com.au</p>	<p><b>CLOVERTON - 328</b> <b>DP3b</b></p> <p><b>100 LOTS</b></p>	<p><b>LICENSED SURVEYOR GREGORY STUART WILLIAMS</b></p> <p><b>DATE</b> 14/03/23 <b>REFERENCE</b> 331637-ST328  <b>VERSION</b> D <b>DRAWING</b> 331637-ST328-AD</p> <p>Digitally signed by: Gregory S Williams, Licensed Surveyor, Surveyor's Plan Version (D), 14/03/2023, SPEAR Ref: S200025E</p>	<p><b>ORIGINAL SHEET SIZE A3</b></p> <p><b>SHEET 1 OF 7 SHEETS</b></p>
--	--	--	--

# PLAN OF SUBDIVISION

PS 905616P

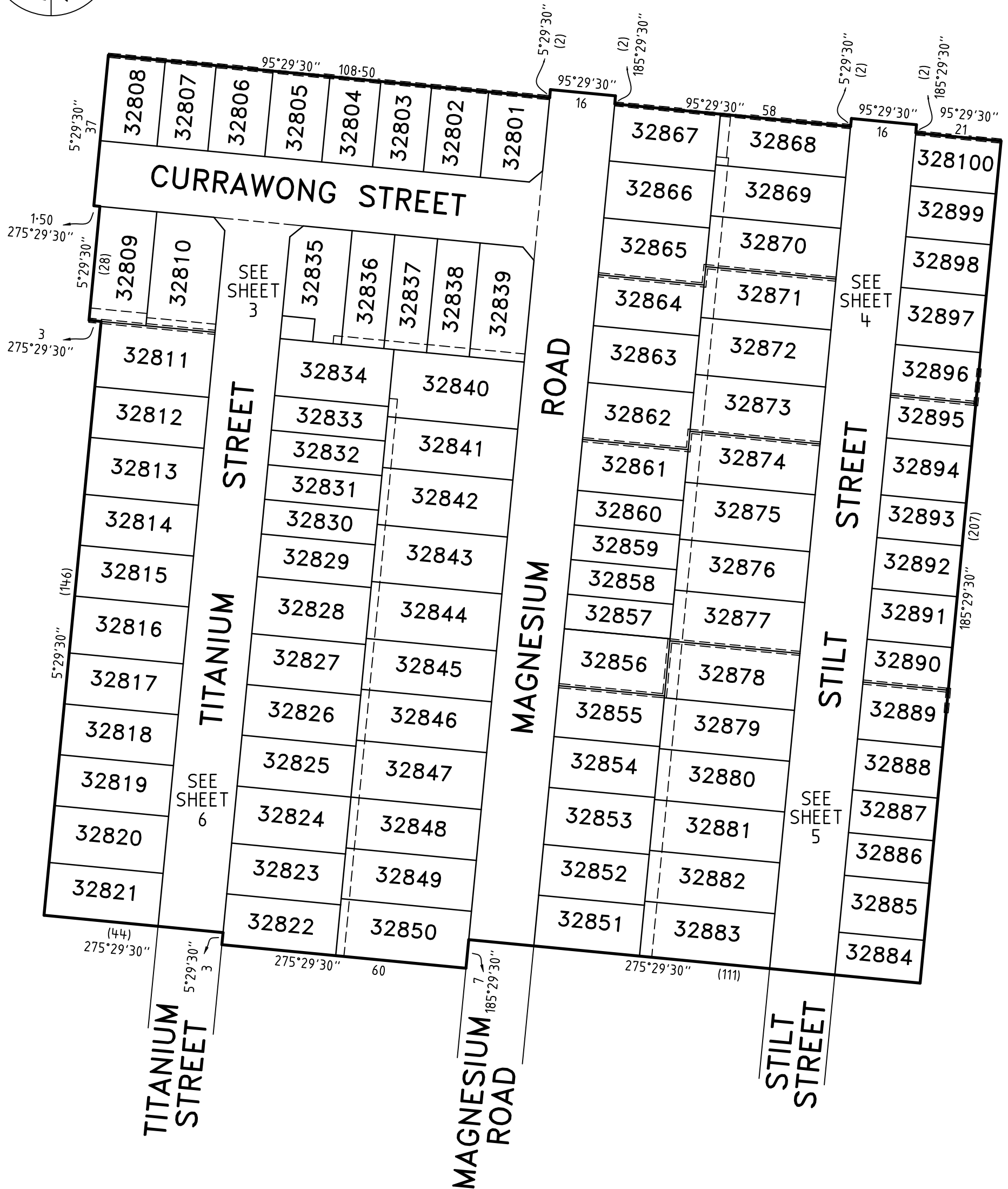
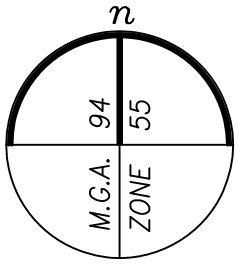

CLOVERTON - 328

DP3b

LICENSED SURVEYOR GREGORY STUART WILLIAMS

SCALE  
1:1000

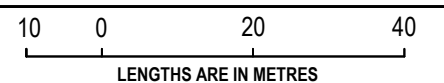

VERIS AUSTRALIA PTY LTD  
A | Level 3, 1 Southbank Blvd  
Southbank VIC 3006  
T | +61 3 7019 8400  
E | melbourne@veris.com.au  
W | www.veris.com.au

DATE 14/03/23

REFERENCE 331637-ST328

ORIGINAL SHEET SIZE A3

VERSION D

DRAWING 331637-ST328-AD

SHEET 2

Digitally signed by: Gregory S Williams, Licensed Surveyor,  
Surveyor's Plan Version (D),  
14/03/2023, SPEAR Ref: S200025E

# PLAN OF SUBDIVISION

PS 905616P

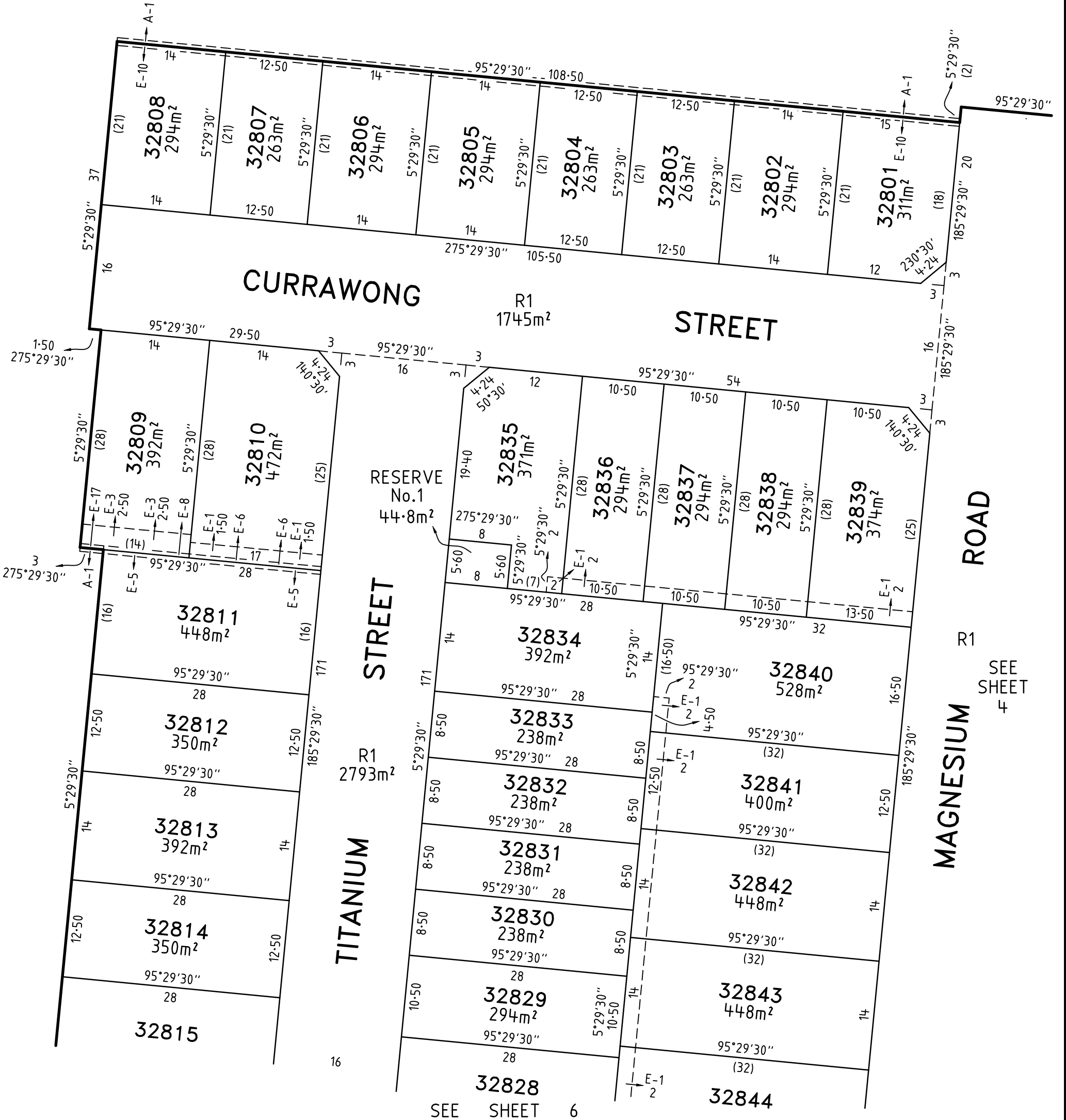
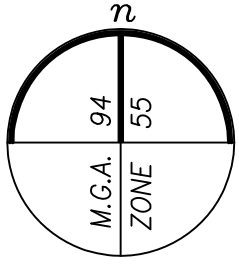

CLOVERTON - 328

DP3b

LICENSED SURVEYOR GREGORY STUART WILLIAMS

SCALE 1:500

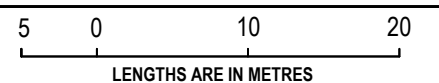

VERIS AUSTRALIA PTY LTD  
 A | Level 3, 1 Southbank Blvd  
 Southbank VIC 3006  
 T | +61 3 7019 8400  
 E | melbourne@veris.com.au  
 W | www.veris.com.au

DATE 14/03/23

REFERENCE 331637-ST328

ORIGINAL SHEET SIZE A3

VERSION D

DRAWING 331637-ST328-AD

SHEET 3

Digitally signed by: Gregory S Williams, Licensed Surveyor,  
 Surveyor's Plan Version (D),  
 14/03/2023, SPEAR Ref: S200025E

# PLAN OF SUBDIVISION

PS 905616P

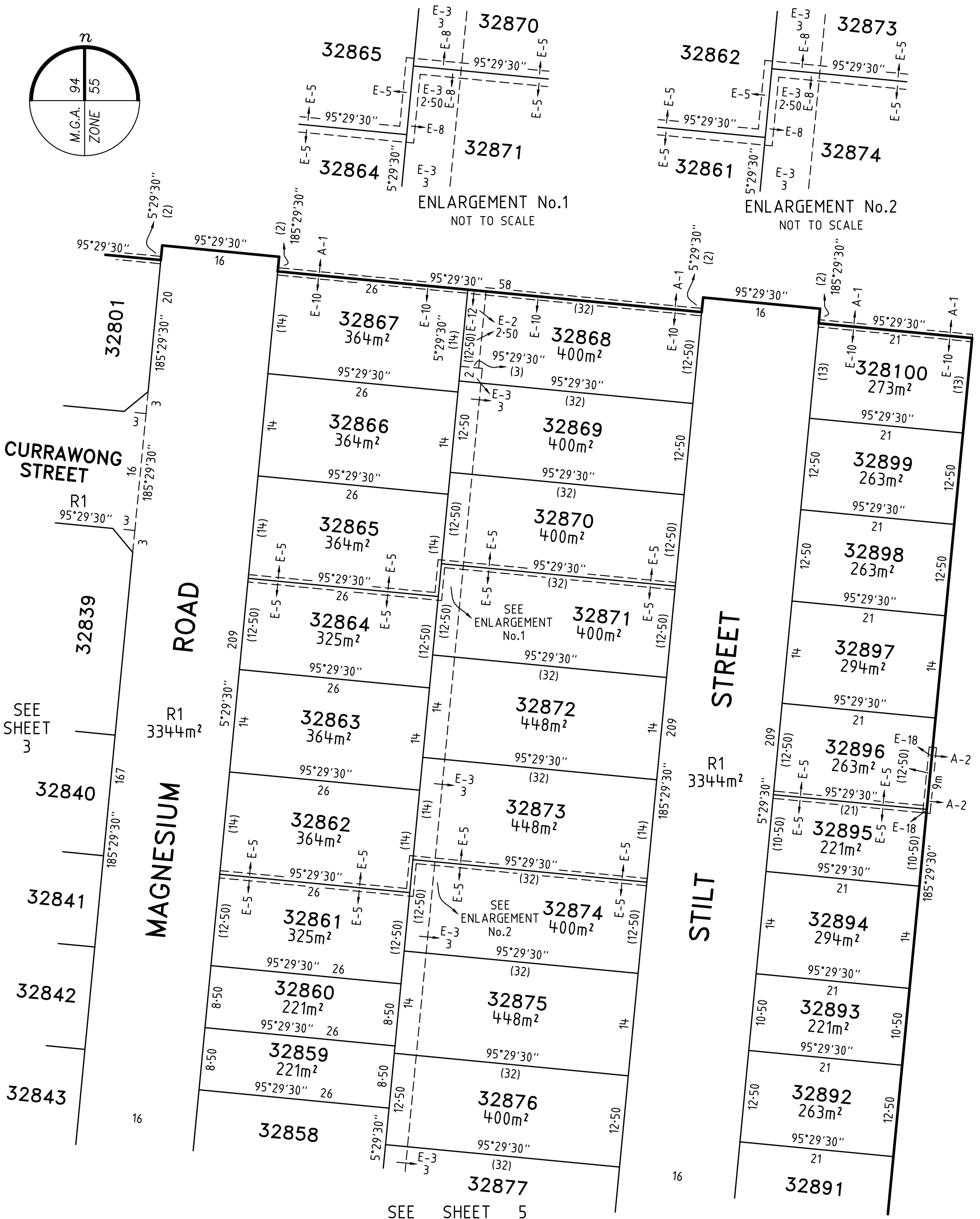
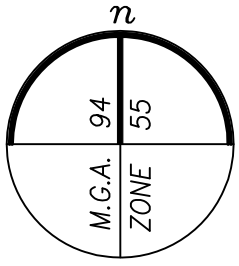

CLOVERTON - 328

DP3b

LICENSED SURVEYOR GREGORY STUART WILLIAMS

SCALE  
1:500

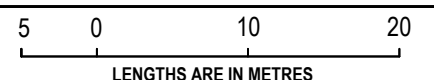

VERIS AUSTRALIA PTY LTD  
A | Level 3, 1 Southbank Blvd  
Southbank VIC 3006  
T | +61 3 7019 8400  
E | melbourne@veris.com.au  
W | www.veris.com.au

DATE 14/03/23

REFERENCE 331637-ST328

VERSION D

DRAWING 331637-ST328-AD

ORIGINAL SHEET SIZE A3

SHEET 4

Digitally signed by: Gregory S Williams, Licensed Surveyor,  
Surveyor's Plan Version (D),  
14/03/2023, SPEAR Ref: S200025E



# PLAN OF SUBDIVISION

PS 905616P

SEE SHEET 4

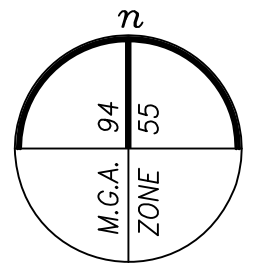
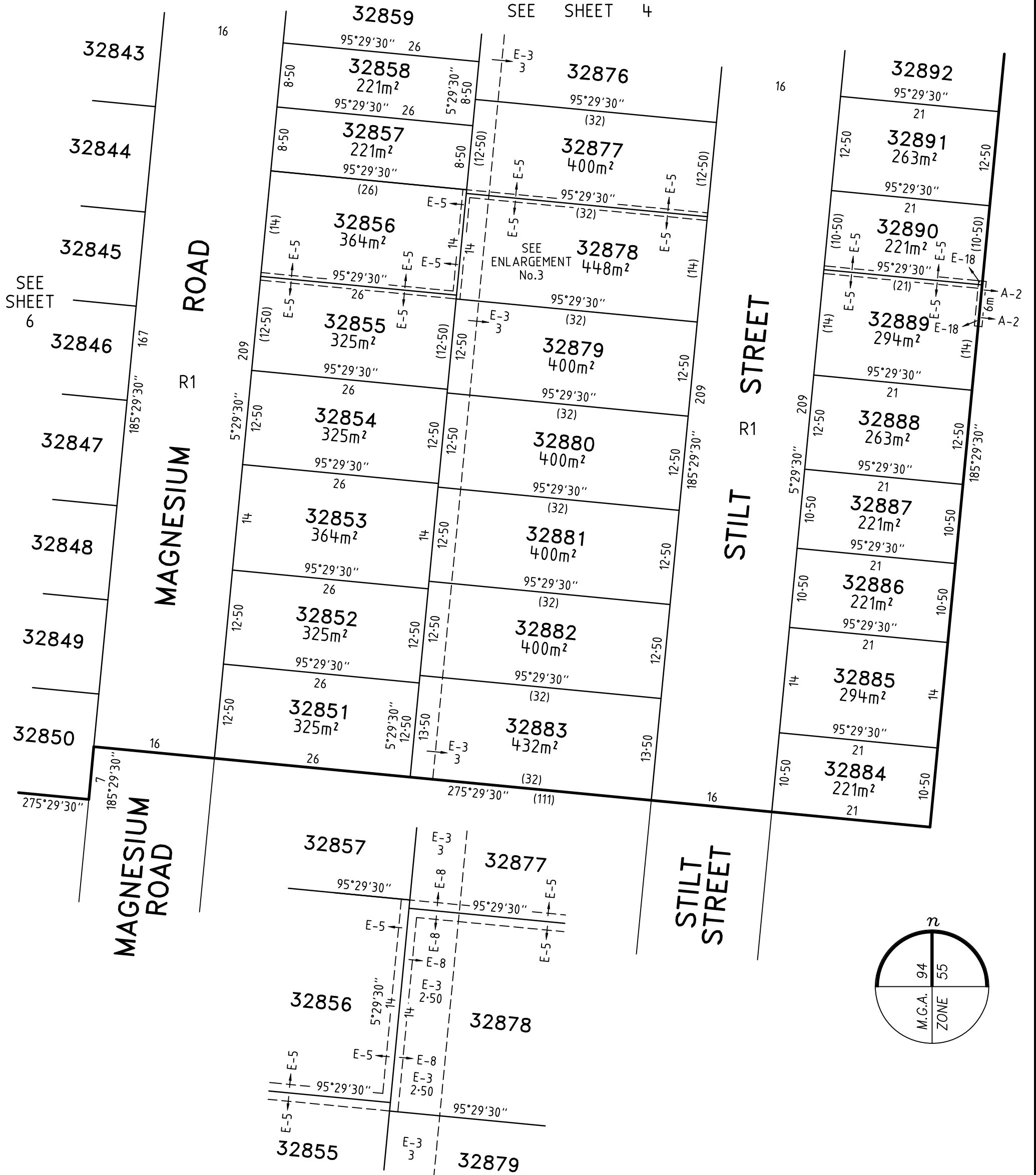

ENLARGEMENT No.3  
NOT TO SCALE

CLOVERTON - 328

DP3b

LICENSED SURVEYOR GREGORY STUART WILLIAMS

SCALE  
1:500

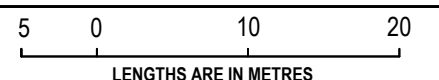

VERIS AUSTRALIA PTY LTD  
A | Level 3, 1 Southbank Blvd  
Southbank VIC 3006  
T | +61 3 7019 8400  
E | melbourne@veris.com.au  
W | www.veris.com.au

DATE 14/03/23

REFERENCE 331637-ST328

VERSION D

DRAWING 331637-ST328-AD

ORIGINAL SHEET SIZE A3

SHEET 5

Digitally signed by: Gregory S Williams, Licensed Surveyor,  
Surveyor's Plan Version (D),  
14/03/2023, SPEAR Ref: S200025E

# PLAN OF SUBDIVISION

PS 905616P

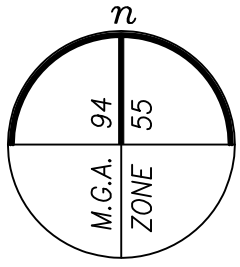

SEE SHEET 3

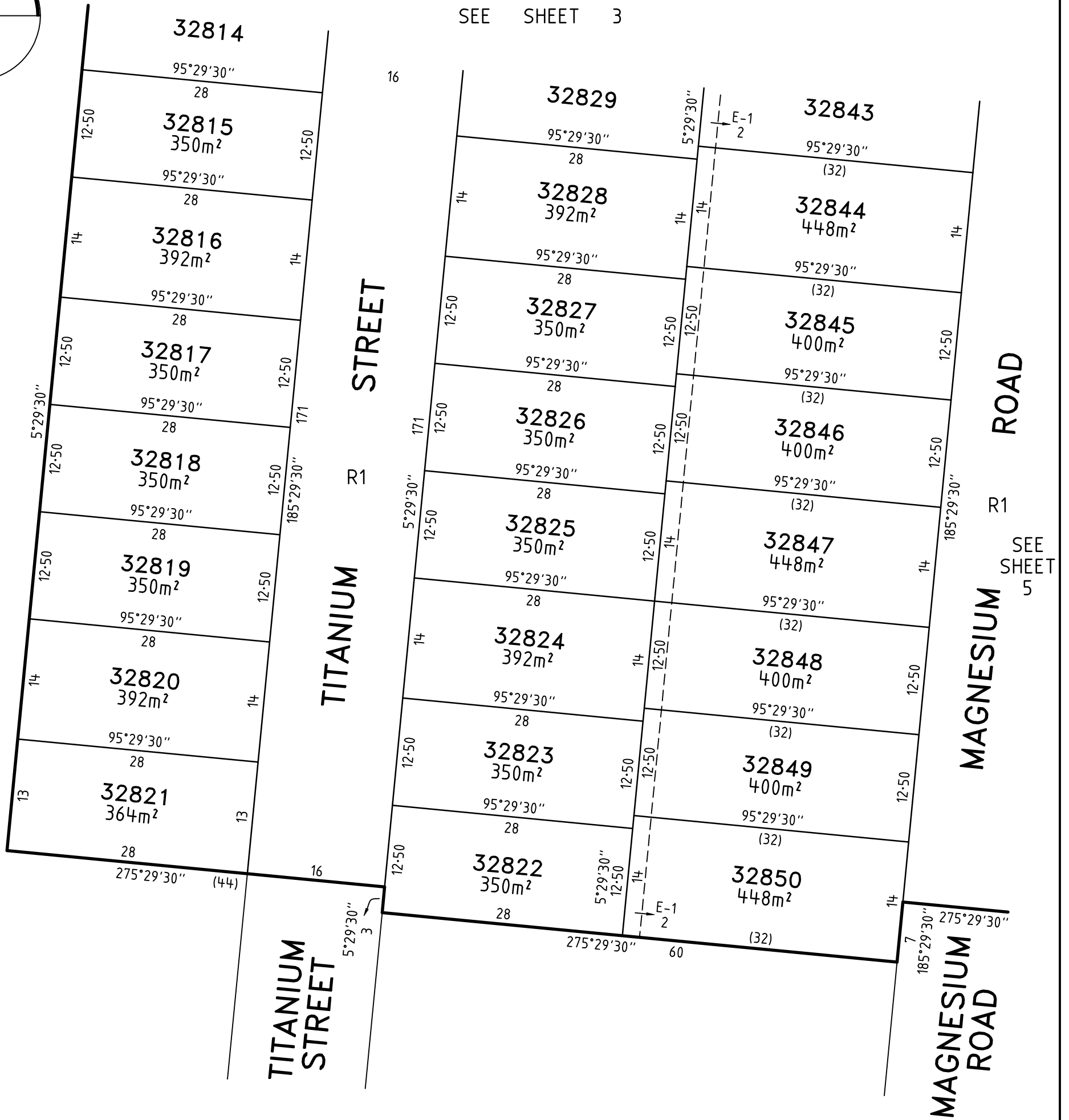

CLOVERTON - 328

DP3b

LICENSED SURVEYOR GREGORY STUART WILLIAMS

SCALE  
1:500

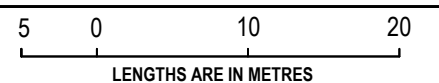

VERIS AUSTRALIA PTY LTD  
A | Level 3, 1 Southbank Blvd  
Southbank VIC 3006  
T | +61 3 7019 8400  
E | melbourne@veris.com.au  
W | www.veris.com.au

DATE 14/03/23

REFERENCE 331637-ST328

ORIGINAL SHEET SIZE A3

VERSION D

DRAWING 331637-ST328-AD

SHEET 6

Digitally signed by: Gregory S Williams, Licensed Surveyor,  
Surveyor's Plan Version (D),  
14/03/2023, SPEAR Ref: S200025E

# PLAN OF SUBDIVISION

**PS 905616P**

## CREATION OF RESTRICTION 'A'

THE REGISTERED PROPRIETORS OF THE BURDENED LAND COVENANT WITH THE REGISTERED PROPRIETORS OF THE BENEFITED LAND AS SET OUT IN THE RESTRICTION WITH THE INTENT THAT THE BURDEN OF THE RESTRICTION RUNS WITH AND BINDS THE BURDENED LAND AND THE BENEFIT OF THE RESTRICTION IS ANNEXED TO AND RUNS WITH THE BENEFITED LAND.

TABLE OF BURDENED AND BENEFITED LAND

BURDENED LOT No.	BENEFITING LOTS ON THIS PLAN
32801	32802
32809	32810, 32811
32810	32809, 32811
32811	32809, 32810, 32812
32812	32811, 32813
32813	32812, 32814
32814	32813, 32815
32815	32814, 32816
32816	32815, 32817
32817	32816, 32818
32818	32817, 32819
32819	32818, 32820
32820	32819, 32821
32821	32820
32822	32823, 32850
32823	32822, 32824, 32849, 32850
32824	32823, 32825, 32848, 32849
32825	32824, 32826, 32847
32826	32825, 32827, 32846, 32847
32827	32826, 32828, 32845, 32846
32828	32827, 32829, 32844, 32845
32834	32833, 32835, 32836, 32837, 32840

BURDENED LOT No.	BENEFITING LOTS ON THIS PLAN
32835	32834, 32836
32839	32838, 32840
32840	32833, 32834, 32837, 32838, 32839, 32841
32841	32832, 32833, 32840, 32842
32842	32830, 32831, 32832, 32841, 32843
32843	32829, 32830, 32842, 32844
32844	32828, 32829, 32843, 32845
32845	32827, 32828, 32844, 32846
32846	32826, 32827, 32845, 32847
32847	32825, 32826, 32846, 32848
32848	32824, 32847, 32849
32849	32823, 32824, 32848, 32850
32850	32822, 32823, 32849
32851	32852, 32883
32852	32851, 32853, 32882, 32883
32853	32852, 32854, 32880, 32881, 32882
32854	32853, 32855, 32879, 32880
32855	32854, 32856, 32878, 32879
32856	32855, 32857, 32877, 32878
32861	32860, 32862, 32874, 32875
32862	32861, 32863, 32873, 32874

BURDENED LOT No.	BENEFITING LOTS ON THIS PLAN
32863	32862, 32864, 32872, 32873
32864	32863, 32865, 32871, 32872
32865	32864, 32866, 32870, 32871
32866	32865, 32867, 32869, 32870
32867	32866, 32868, 32869
32868	32867, 32869
32869	32866, 32867, 32868, 32870
32870	32865, 32866, 32869, 32871
32871	32864, 32865, 32870, 32872
32872	32863, 32864, 32871, 32873
32873	32862, 32863, 32872, 32874
32874	32861, 32862, 32873, 32875
32875	32859, 32860, 32861, 32874, 32876
32876	32858, 32859, 32875, 32877
32877	32856, 32857, 32858, 32876, 32878
32878	32855, 32856, 32877, 32879
32879	32854, 32855, 32878, 32880
32880	32853, 32854, 32879, 32881
32881	32853, 32880, 32882
32882	32852, 32853, 32881, 32883
32883	32851, 32852, 32882

**RESTRICTION:**

THE BURDENED LAND CANNOT BE USED EXCEPT IN ACCORDANCE WITH THE PROVISIONS RECORDED IN MCP.....

EXPIRY DATE: 01/01/2029

## CREATION OF RESTRICTION 'B'

THE REGISTERED PROPRIETORS OF THE BURDENED LAND COVENANT WITH THE REGISTERED PROPRIETORS OF THE BENEFITED LAND AS SET OUT IN THE RESTRICTION WITH THE INTENT THAT THE BURDEN OF THE RESTRICTION RUNS WITH AND BINDS THE BURDENED LAND AND THE BENEFIT OF THE RESTRICTION IS ANNEXED TO AND RUNS WITH THE BENEFITED LAND.

TABLE OF BURDENED AND BENEFITED LAND

BURDENED LOT SUBJECT TO TYPE 'A' OF THE SMALL LOT HOUSING CODE	BENEFITING LOTS ON THIS PLAN
32802	32801, 32803
32803	32802, 32804
32804	32803, 32805
32805	32804, 32806
32806	32805, 32807
32807	32806, 32808
32808	32807
32829	32828, 32830, 32843, 32844
32830	32829, 32831, 32842, 32843
32831	32830, 32832, 32842
32832	32831, 32833, 32841, 32842
32833	32832, 32834, 32840, 32841

BURDENED LOT SUBJECT TO TYPE 'A' OF THE SMALL LOT HOUSING CODE	BENEFITING LOTS ON THIS PLAN
32836	32834, 32835, 32837
32837	32834, 32836, 32838, 32840
32838	32837, 32839, 32840
32857	32856, 32858, 32877
32858	32857, 32859, 32876, 32877
32859	32858, 32860, 32875, 32876
32860	32859, 32861, 32875
32884	32885
32885	32884, 32886
32886	32885, 32887
32887	32886, 32888
32888	32887, 32889

BURDENED LOT SUBJECT TO TYPE 'A' OF THE SMALL LOT HOUSING CODE	BENEFITING LOTS ON THIS PLAN
32889	32888, 32890
32890	32889, 32891
32891	32890, 32892
32892	32891, 32893
32893	32892, 32894
32894	32893, 32895
32895	32894, 32896
32896	32895, 32897
32897	32896, 32898
32898	32897, 32899
32899	32898, 328100
328100	32899

**RESTRICTION:**

THE REGISTERED PROPRIETOR OR PROPRIETORS FOR THE TIME BEING OF ANY BURDENED LOT ON THIS PLAN

- MUST NOT BUILD OR PERMIT TO BE BUILT OR REMAIN ON THE LOT ANY BUILDING OR STRUCTURE THAT HAS NOT BEEN CONSTRUCTED IN ACCORDANCE WITH LOT TYPE 'A' OF THE SMALL LOT HOUSING CODE UNLESS A SPECIFIC PLANNING PERMIT FOR THE SAID DWELLING HAS BEEN OBTAINED FROM THE RESPONSIBLE AUTHORITY.
- SHALL NOT ERECT ANY BUILDINGS ON THE LOT UNLESS THE PLANS FOR SUCH BUILDINGS ARE ENDORSED BY STOCKLAND DEVELOPMENT PTY LTD PRIOR TO THE ISSUE OF THE BUILDING PERMIT, THE REQUIREMENT FOR SUCH ENDORSEMENT CEASING TO HAVE EFFECT ON THE LOT ONE YEAR AFTER AN OCCUPANCY PERMIT UNDER THE BUILDING ACT 1993 IS ISSUED FOR THE WHOLE OF THE DWELLING ON THAT LOT.

EXPIRY DATE: 01/01/2029

**CLOVERTON - 328**

**DP3b**

LICENSED SURVEYOR **GREGORY STUART WILLIAMS**

SCALE



**VERIS AUSTRALIA PTY LTD**  
 A | Level 3, 1 Southbank Blvd  
 Southbank VIC 3006  
 T | +61 3 7019 8400  
 E | melbourne@veris.com.au  
 W | www.veris.com.au

DATE 14/03/23

REFERENCE 331637-ST328

VERSION D

DRAWING 331637-ST328-AD

ORIGINAL SHEET SIZE A3

SHEET 7

Digitally signed by: Gregory S Williams, Licensed Surveyor,  
 Surveyor's Plan Version (D),  
 14/03/2023, SPEAR Ref: S200025E



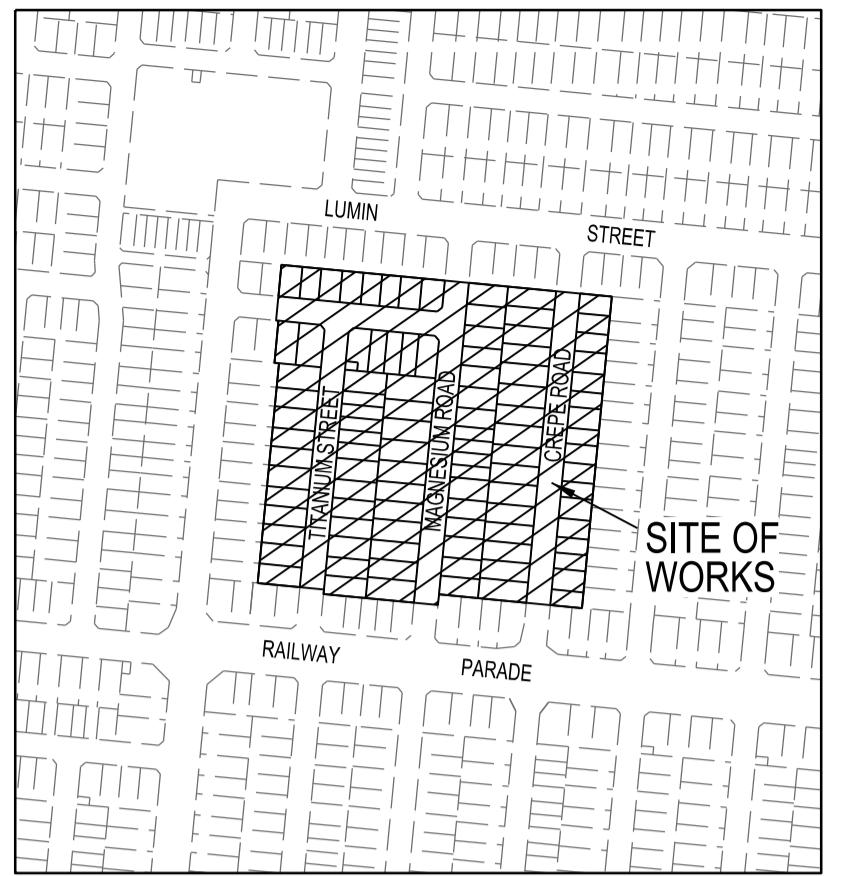
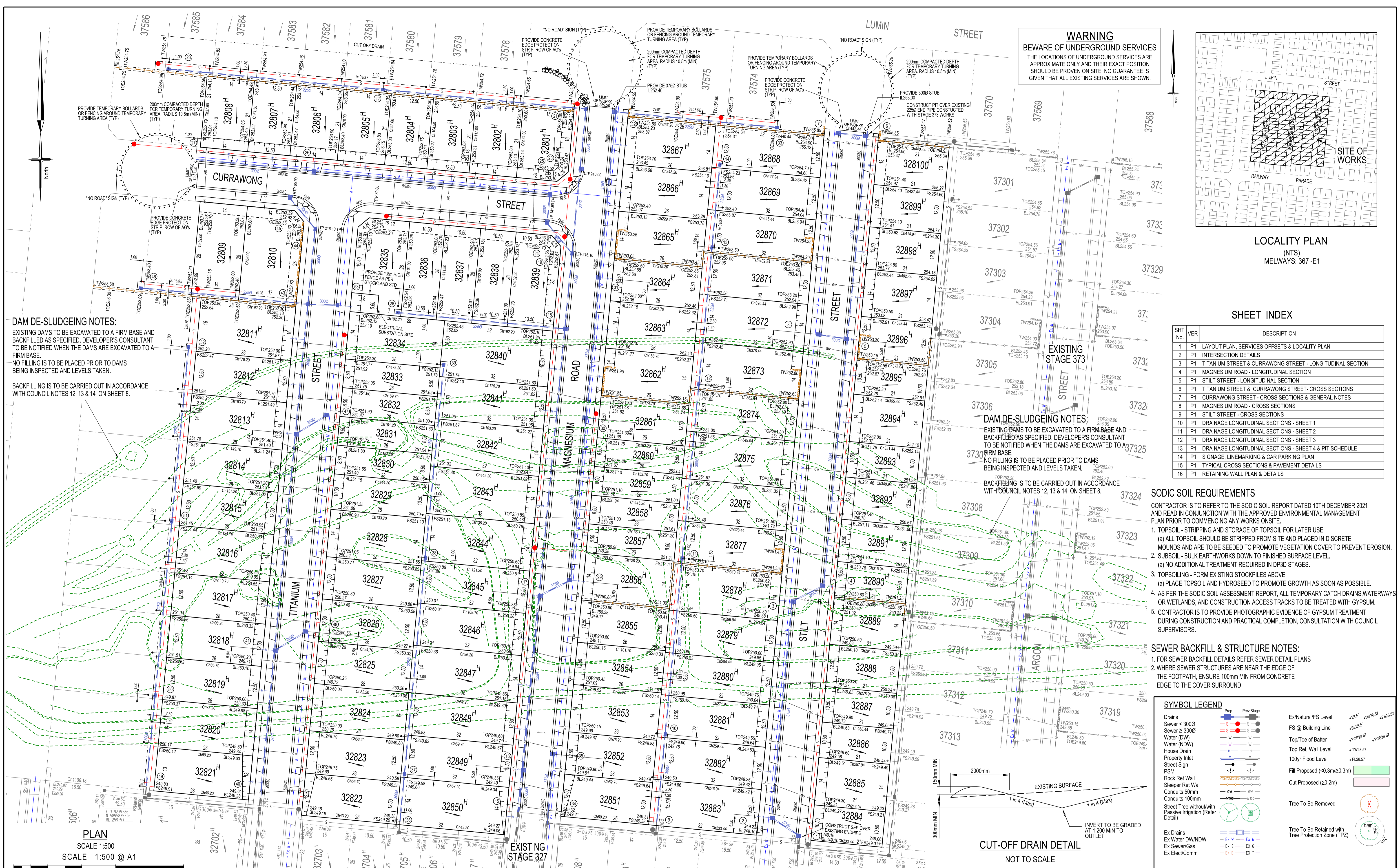

LOCALITY PLAN (NTS)  
MELWAYS: 367-E1

SHEET INDEX

SHT No.	VER	DESCRIPTION
1	P1	LAYOUT PLAN, SERVICES OFFSETS & LOCALITY PLAN
2	P1	INTERSECTION DETAILS
3	P1	TITANIUM STREET & CURRAWONG STREET - LONGITUDINAL SECTION
4	P1	MAGNESIUM ROAD - LONGITUDINAL SECTION
5	P1	STILT STREET - LONGITUDINAL SECTION
6	P1	TITANIUM STREET & CURRAWONG STREET - CROSS SECTIONS
7	P1	CURRAWONG STREET - CROSS SECTIONS & GENERAL NOTES
8	P1	MAGNESIUM ROAD - CROSS SECTIONS
9	P1	STILT STREET - CROSS SECTIONS
10	P1	DRAINAGE LONGITUDINAL SECTIONS - SHEET 1
11	P1	DRAINAGE LONGITUDINAL SECTIONS - SHEET 2
12	P1	DRAINAGE LONGITUDINAL SECTIONS - SHEET 3
13	P1	DRAINAGE LONGITUDINAL SECTIONS - SHEET 4 & PIT SCHEDULE
14	P1	SIGNAGE, LINEMARKING & CAR PARKING PLAN
15	P1	TYPICAL CROSS SECTIONS & PAVEMENT DETAILS
16	P1	RETAINING WALL PLAN & DETAILS

**SODIC SOIL REQUIREMENTS**  
CONTRACTOR IS TO REFER TO THE SODIC SOIL REPORT DATED 10TH DECEMBER 2021 AND READ IN CONJUNCTION WITH THE APPROVED ENVIRONMENTAL MANAGEMENT PLAN PRIOR TO COMMENCING ANY WORKS ON SITE.

- TOPSOIL - STRIPPING AND STORAGE OF TOPSOIL FOR LATER USE.
  - (a) ALL TOPSOIL SHOULD BE STRIPPED FROM SITE AND PLACED IN DISCRETE MOUNDS AND ARE TO BE SEED TO PROMOTE VEGETATION COVER TO PREVENT EROSION.
- SUBSOIL - BULK EARTHWORKS DOWN TO FINISHED SURFACE LEVEL.
  - (a) NO ADDITIONAL TREATMENT REQUIRED IN DP30 STAGES.
- TOPSOILING - FORM EXISTING STOCKPILES ABOVE.
  - (a) PLACE TOPSOIL AND HYDROSEED TO PROMOTE GROWTH AS SOON AS POSSIBLE.
- AS PER THE SODIC SOIL ASSESSMENT REPORT, ALL TEMPORARY CATCH DRAINS, WATERWAYS OR WETLANDS, AND CONSTRUCTION ACCESS TRACKS TO BE TREATED WITH GYPSUM.
- CONTRACTOR IS TO PROVIDE PHOTOGRAPHIC EVIDENCE OF GYPSUM TREATMENT DURING CONSTRUCTION AND PRACTICAL COMPLETION. CONSULTATION WITH COUNCIL SUPERVISORS.

**SEWER BACKFILL & STRUCTURE NOTES:**

- FOR SEWER BACKFILL DETAILS REFER SEWER DETAIL PLANS
- WHERE SEWER STRUCTURES ARE NEAR THE EDGE OF THE FOOTPATH, ENSURE 100mm MIN FROM CONCRETE EDGE TO THE COVER SURROUND

**SYMBOL LEGEND**

Drains	Prop	Prev Stage	Ex/Natural/FS Level	+28.57	+28.08	+28.07
Sewer < 3000	—	—	FS @ Building Line	+28.28	—	—
Sewer ≥ 3000	—	—	Top/Toe of Batter	+28.27	+28.27	+28.27
Water (DW)	—	—	Top Ret. Wall Level	+28.27	—	—
Water (NDW)	—	—	100yr Flood Level	+28.27	—	—
House Drain	—	—	Fill Proposed (<0.3m/20.3m)	—	—	—
Property Inlet	—	—	Cut Proposed (±0.2m)	—	—	—
Street Sign	—	—	Tree To Be Removed	—	—	—
PSM	—	—	Tree To Be Retained with Tree Protection Zone (TPZ)	—	—	—
Rock Ret Wall	—	—	—	—	—	—
Sloper Ret Wall	—	—	—	—	—	—
Conduits 50mm	—	—	—	—	—	—
Conduits 100mm	—	—	—	—	—	—
Street Tree without/with Passive Irrigation (Refer Detail)	—	—	—	—	—	—
Ex Drains	—	—	—	—	—	—
Ex Water/DW/NDW	—	—	—	—	—	—
Ex Sewer/Gas	—	—	—	—	—	—
Ex Elect/Comm	—	—	—	—	—	—

**DAM DE-SLUDGING NOTES:**  
EXISTING DAMS TO BE EXCAVATED TO A FIRM BASE AND BACKFILLED AS SPECIFIED. DEVELOPER'S CONSULTANT TO BE NOTIFIED WHEN THE DAMS ARE EXCAVATED TO A FIRM BASE.  
NO FILLING IS TO BE PLACED PRIOR TO DAMS BEING INSPECTED AND LEVELS TAKEN.  
BACKFILLING IS TO BE CARRIED OUT IN ACCORDANCE WITH COUNCIL NOTES 12, 13 & 14 ON SHEET 8.

**DAM DE-SLUDGING NOTES:**  
EXISTING DAMS TO BE EXCAVATED TO A FIRM BASE AND BACKFILLED AS SPECIFIED. DEVELOPER'S CONSULTANT TO BE NOTIFIED WHEN THE DAMS ARE EXCAVATED TO A FIRM BASE.  
NO FILLING IS TO BE PLACED PRIOR TO DAMS BEING INSPECTED AND LEVELS TAKEN.  
BACKFILLING IS TO BE CARRIED OUT IN ACCORDANCE WITH COUNCIL NOTES 12, 13 & 14 ON SHEET 8.

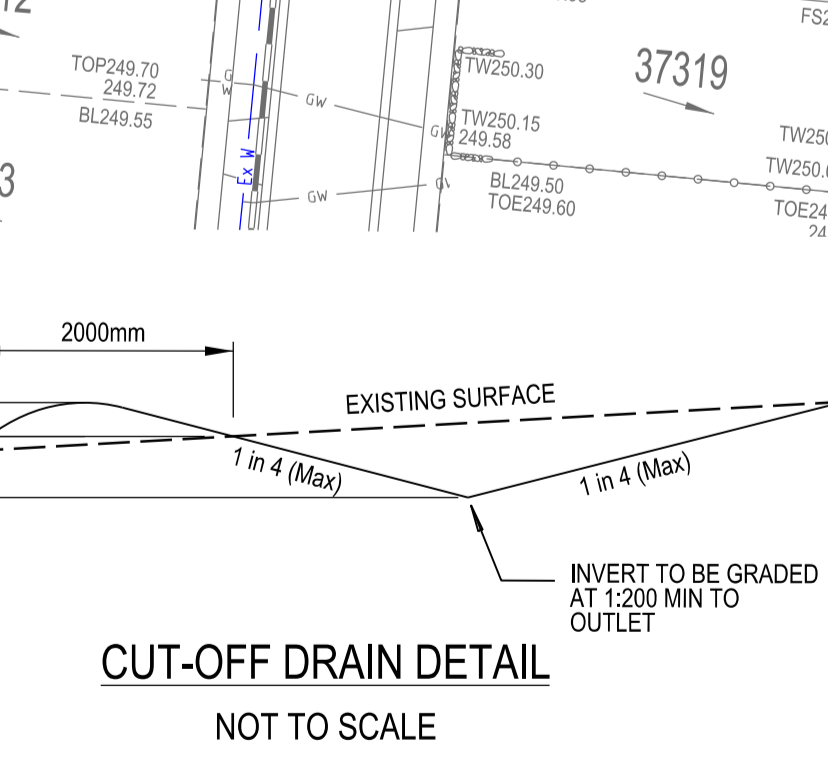

PLAN  
SCALE 1:500  
SCALE 1:500 @ A1  
LENGTHS ARE IN METRES

**SERVICES OFFSETS AND LOCATIONS**

Location	Gas	Water		Telecommunications		Electricity		BOK	Road Width	Joint Trenching	Street Classification
		NDW	DW	Cables	Pits	Cables	Poles				
TITANIUM STREET	2.10 E	2.50 E	3.00 E	1.85 W	1.85 W	2.20 W	1.00 BOK	3.90 W 4.20 E	16.00	G NDW DW & E NBN	ACCESS STREET LVL 1
CURRAWONG STREET	2.10 N	2.50 N	3.00 N	1.85 S	1.85 S	2.20 S	1.00 BOK	3.90 S 4.20 N	16.00	G NDW DW & E NBN	ACCESS STREET LVL 1
MAGNESIUM ROAD	2.10 E	2.50 E	3.00 E	1.85 W	1.85 W	2.20 W	1.00 BOK	3.90 W 4.20 E	16.00	G NDW DW & E NBN	ACCESS STREET LVL 1
STILT STREET	2.10 W	2.50 W	3.00 W	1.85 E	1.85 E	2.20 E	1.00 BOK	3.90 E 4.20 W	16.00	G NDW DW & E NBN	ACCESS STREET LVL 1

**ATTENTION TO CONTRACTOR**

- IT IS THE CONTRACTORS RESPONSIBILITY TO ENSURE THAT THE DIGITAL PLAN, PROVIDED FOR SETOUT PURPOSES, MATCHES THE TBM COORDINATES SHOWN.
- Contractor to ensure that the site is pegged and/or set out checked by the licenced surveyor responsible for certifying the Plan of Subdivision prior to underground infrastructure being installed.
- Where concrete works about a sewer access chamber surround or similar structure, an expansion joint of approved material shall be provided between the two faces.

**breese pitt dixon pty. ltd.**  
land surveyors civil engineers

1/19 cato street hawthorn east, 3123 telephone 8823 2300 fax no. 8823 2310

**CLOVERTON ESTATE STAGE 328**  
LAYOUT PLAN AND DETAILS

MELWAY REF. 367-F-3  
SURVEY VERIS  
DESIGN R.W.  
DRAWN D.W.  
CHECKED A.K.

AMENDMENTS

VER	DATE	REMARKS

MUNICIPALITY HUME  
REFERENCE 8460 E/328  
SCALE AS SHOWN DATUM AHD  
DATE AUG '22 SHEET 1 OF 16 P1



VC LENGTH	3.65% 3.65% 5.27% 0.50% 0.50%				
KERB GRADING	6.75m V.C. 6.75m V.C.				
DATUM 251.5					
LIP OF KERB	252.518	252.701	252.888	253.002	253.222
LIP CHAINAGE	-5.000	0.000	3.377	6.754	10.132

LIP LINE H

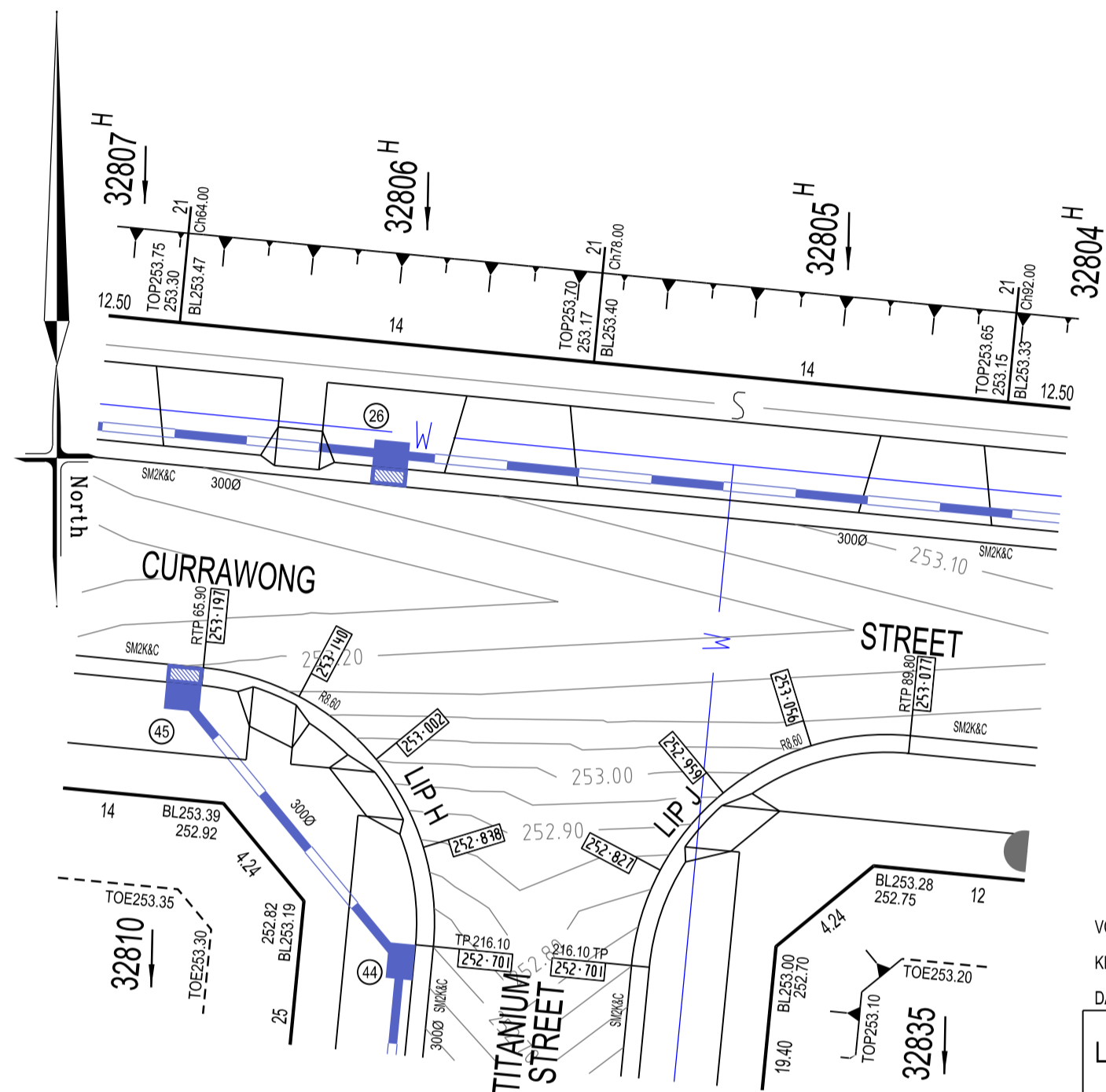

VC LENGTH	0.50% 0.50% -4.00% -3.65% -3.65%				
KERB GRADING	6.75m V.C. 6.75m V.C.				
DATUM 251.5					
LIP OF KERB	253.052	253.077	253.079	252.869	252.701
LIP CHAINAGE	-5.000	0.000	0.351	3.377	6.754

LIP LINE J

VC LENGTH	6.75m V.C. 6.75m V.C.				
KERB GRADING	-0.50% 0.50% 4.78% 3.93% 3.93%				
DATUM 251.75					
LIP OF KERB	252.842	252.817	252.870	252.895	253.149
LIP CHAINAGE	-5.000	0.000	3.377	6.754	10.132

LIP LINE L

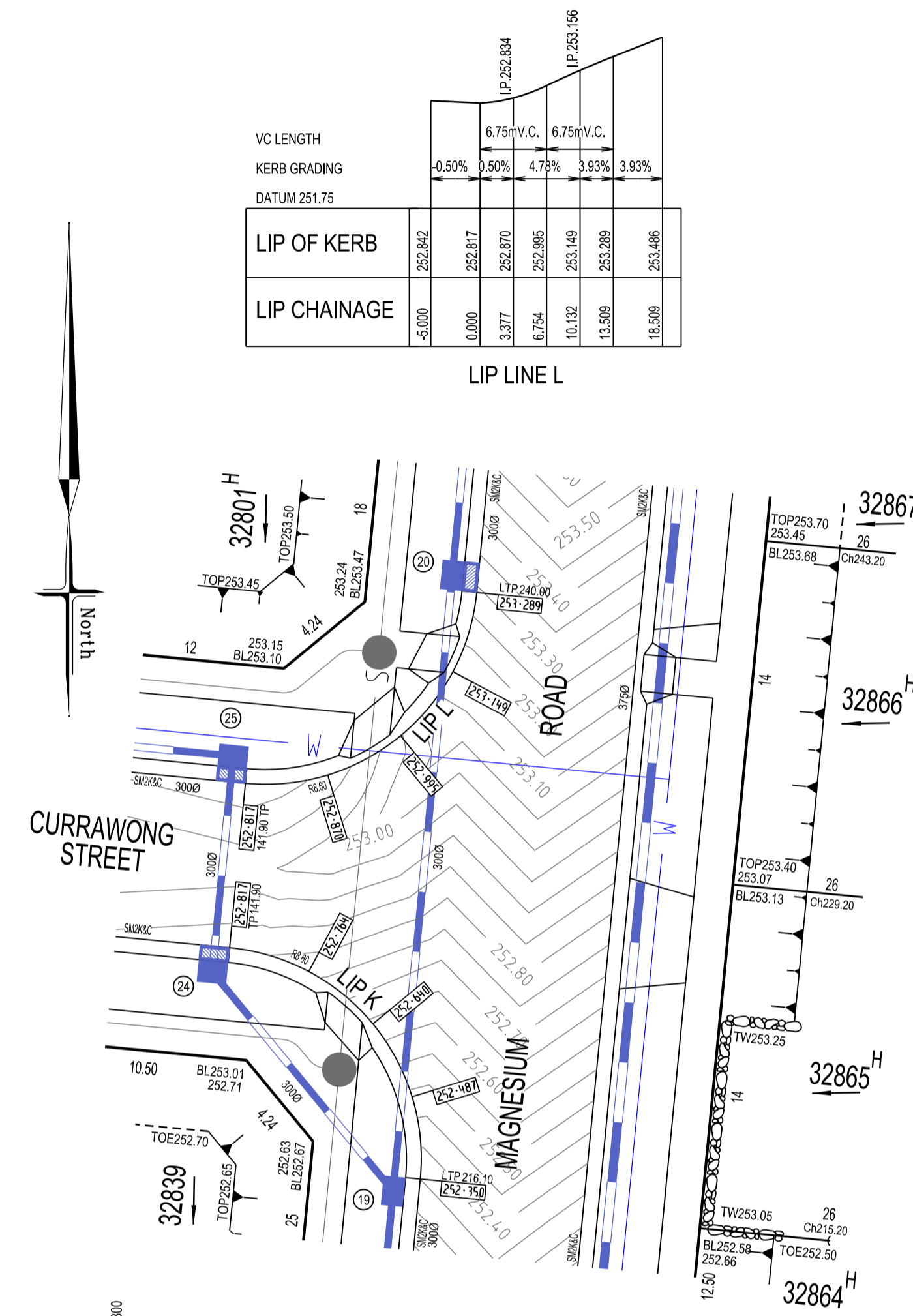

VC LENGTH	3.63% 3.63% 4.74% 0.50% 0.50%				
KERB GRADING	6.75m V.C. 6.75m V.C.				
DATUM 251					
LIP OF KERB	252.189	252.260	252.487	252.640	252.764
LIP CHAINAGE	-5.000	0.000	3.377	6.754	10.132

LIP LINE K

PLAN  
SCALE 1:200

SCALE 1:200 @ A1

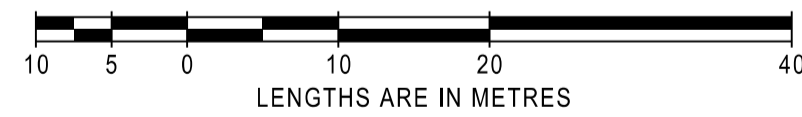

SYMBOL LEGEND	
Drains	Prop Prev Stage
Sewer < 3000	S S
Sewer ≥ 3000	S S
Water (DW)	W W
House Drain	W W
Property Inlet	W W
Street Sign	W W
PSM	W W
Rock Ret Wall	W W
Sleeper Ret Wall	W W
Conduits 50mm	W W
Conduits 100mm	W W
Street Tree without/with Passive Irrigation (Refer Detail)	W W
Ex Drains	W W
Ex Water/DW/DW	W W
Ex Sewer/Gas	W W
Ex Elect/Comm	W W
Ex/Natural/FS Level	• 28.57 • N28.57 • F28.57
FS @ Building Line	• BL28.57
Top/Toe of Batter	• TOP28.57 • TOE28.57
Top Ret. Wall Level	• TW28.57
100yr Flood Level	• FL28.57
Fill Proposed (<0.3m/≥0.3m)	■
Cut Proposed (≥0.2m)	■
Tree To Be Removed	⊗
Tree To Be Retained with Tree Protection Zone (TPZ)	⊙

ALL SETOUT DETAILS ARE PROVIDED AT LIP OF KERB

**WARNING**  
BEWARE OF UNDERGROUND SERVICES  
THE LOCATIONS OF UNDERGROUND SERVICES ARE APPROXIMATE ONLY AND THEIR EXACT POSITION SHOULD BE PROVEN ON SITE. NO GUARANTEE IS GIVEN THAT ALL EXISTING SERVICES ARE SHOWN.

AMENDMENTS			 breese pitt dixon pty. ltd. land surveyors civil engineers	1/19 cato street hawthorn east, 3123 telephone 8823 2300 fax no. 8823 2310	
				<b>CLOVERTON ESTATE STAGE 328 INTERSECTION DETAILS</b>	MUNICIPALITY <b>HUME</b>
					REFERENCE 8460 E/328
					MELWAY REF. 386-F-3 SURVEY VERIS DESIGN R.W. DRAWN D.W. CHECKED A.K.
VER	DATE	REMARKS			

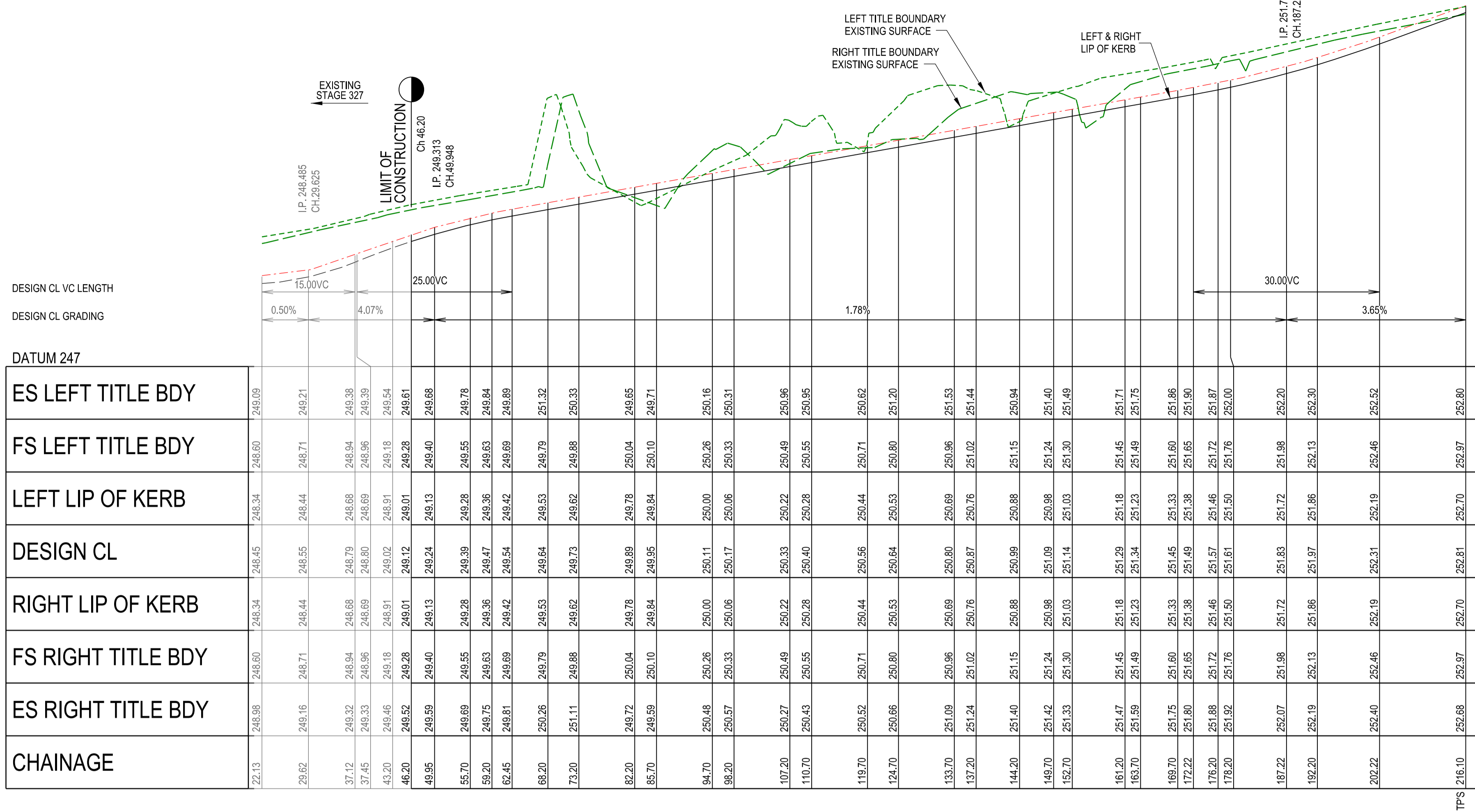

ES LEFT TITLE BDY	FS LEFT TITLE BDY	LEFT LIP OF KERB	DESIGN CL	RIGHT LIP OF KERB	FS RIGHT TITLE BDY	ES RIGHT TITLE BDY	CHAINAGE
248.09	248.60	248.34	248.45	248.34	248.60	248.98	22.13
249.21	248.71	248.44	248.55	248.44	248.71	249.16	29.62
249.38	248.94	248.68	248.79	248.68	248.94	249.32	37.12
249.39	248.96	248.69	248.80	248.69	248.96	249.33	37.45
249.54	249.18	248.91	249.02	248.91	249.18	249.46	43.20
249.61	249.28	249.01	249.12	249.01	249.28	249.52	46.20
249.68	249.40	249.13	249.24	249.13	249.40	249.59	49.95
249.78	249.55	249.28	249.39	249.28	249.55	249.69	55.70
249.84	249.63	249.47	249.47	249.36	249.63	249.75	59.20
249.89	249.69	249.42	249.54	249.42	249.69	249.81	62.45
251.32	249.79	249.53	249.64	249.53	249.79	250.26	68.20
250.33	249.88	249.62	249.73	249.62	249.88	251.11	73.20
249.85	250.04	249.78	249.89	249.78	250.04	249.72	82.20
249.71	250.10	249.84	249.95	249.84	250.10	249.59	85.70
250.16	250.26	250.00	250.11	250.00	250.26	250.48	94.70
250.31	250.33	250.06	250.17	250.06	250.33	250.57	98.20
250.96	250.49	250.22	250.33	250.22	250.49	250.27	107.20
250.95	250.55	250.28	250.40	250.28	250.55	250.43	110.70
250.82	250.71	250.44	250.56	250.44	250.71	250.52	119.70
251.20	250.80	250.53	250.64	250.53	250.80	250.66	124.70
251.53	250.96	250.69	250.80	250.69	250.96	251.09	133.70
251.44	251.02	250.76	250.87	250.76	251.02	251.24	137.20
250.94	251.15	250.88	250.99	250.88	251.15	251.40	144.20
251.40	251.24	250.98	251.09	250.98	251.24	251.42	148.70
251.49	251.30	251.03	251.14	251.03	251.30	251.33	152.70
251.71	251.45	251.18	251.29	251.18	251.45	251.47	161.20
251.75	251.49	251.23	251.34	251.23	251.49	251.59	163.70
251.86	251.60	251.33	251.45	251.33	251.60	251.75	168.70
251.90	251.65	251.38	251.49	251.38	251.65	251.80	172.22
251.87	251.72	251.46	251.57	251.46	251.72	251.88	176.20
252.00	251.76	251.50	251.61	251.50	251.76	251.92	178.20
252.20	251.98	251.72	251.83	251.72	251.98	252.07	187.22
252.30	252.13	251.86	251.97	251.86	252.13	252.19	192.20
252.52	252.46	252.19	252.31	252.19	252.46	252.40	202.22
252.80	252.97	252.70	252.81	252.70	252.97	252.68	TPS 216.10

TITANIUM STREET

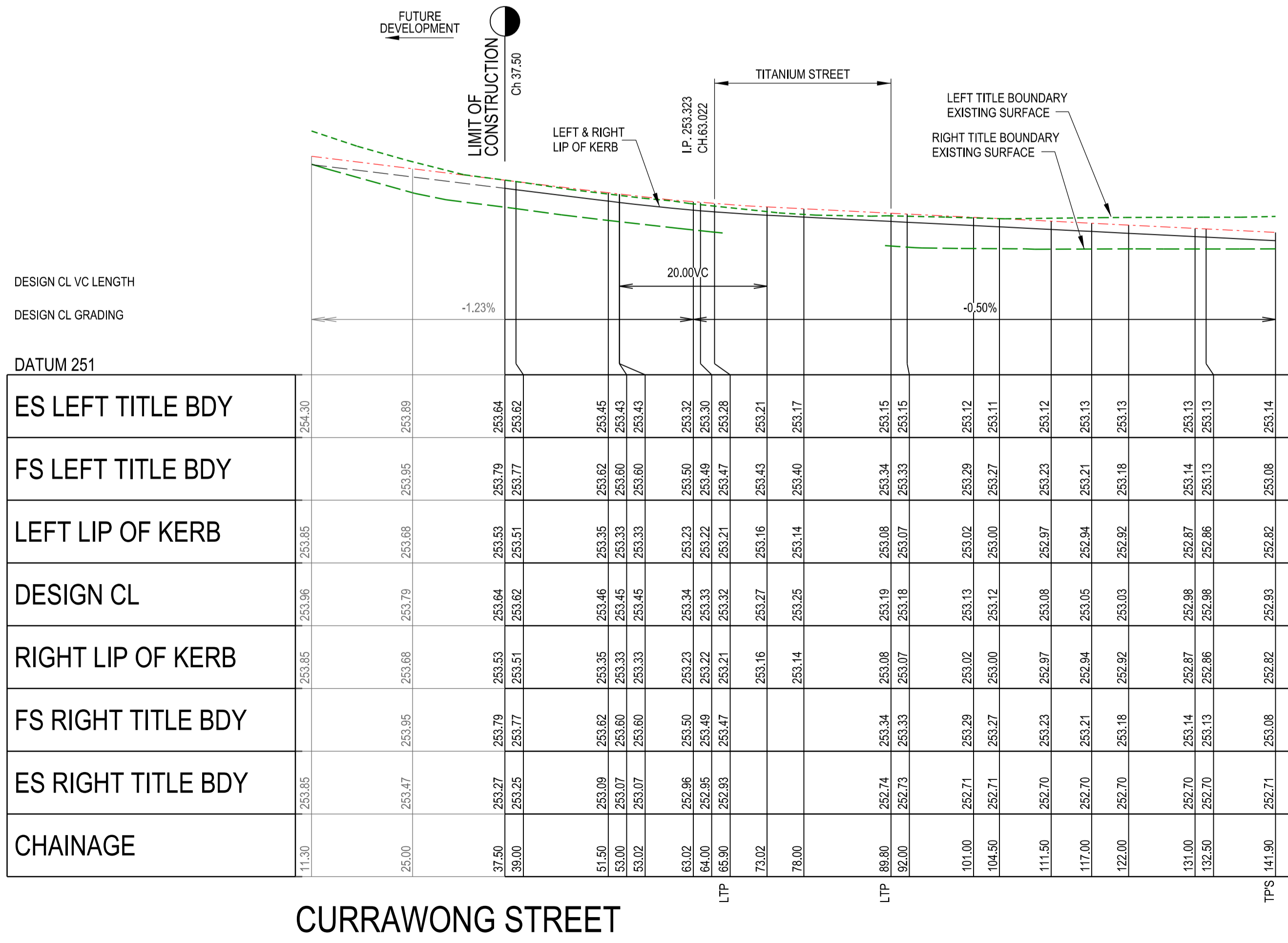

ES LEFT TITLE BDY	FS LEFT TITLE BDY	LEFT LIP OF KERB	DESIGN CL	RIGHT LIP OF KERB	FS RIGHT TITLE BDY	ES RIGHT TITLE BDY	CHAINAGE
253.30	253.85	253.85	253.96	253.85	253.85	253.85	11.30
253.89	253.95	253.68	253.79	253.68	253.95	253.47	25.00
253.64	253.79	253.53	253.64	253.53	253.79	253.27	37.50
253.62	253.77	253.51	253.62	253.51	253.77	253.25	39.00
253.45	253.62	253.35	253.46	253.35	253.62	253.09	51.50
253.43	253.60	253.33	253.45	253.33	253.60	253.07	53.00
253.43	253.60	253.33	253.45	253.33	253.60	253.07	53.02
253.32	253.50	253.23	253.34	253.23	253.50	252.96	63.02
253.30	253.49	253.22	253.33	253.22	253.49	252.95	64.00
253.28	253.47	253.21	253.32	253.21	253.47	252.93	65.90
253.21	253.43	253.16	253.27	253.16	253.43	253.02	73.02
253.17	253.40	253.14	253.25	253.14	253.40	252.74	78.00
253.15	253.34	253.08	253.19	253.08	253.34	252.74	89.80
253.15	253.33	253.07	253.18	253.07	253.33	252.73	92.00
253.12	253.29	253.02	253.13	253.02	253.29	252.71	101.00
253.11	253.27	253.00	253.12	253.00	253.27	252.71	104.50
253.12	253.23	252.97	253.08	252.97	253.23	252.70	111.50
253.13	253.21	252.94	253.05	252.94	253.21	252.70	117.00
253.13	253.18	252.92	253.03	252.92	253.18	252.70	122.00
253.13	253.14	252.87	252.98	252.87	253.14	252.70	131.00
253.13	253.13	252.86	252.98	252.86	253.13	252.70	132.50
253.14	253.08	252.82	252.93	252.82	253.08	252.71	141.90

CURRAWONG STREET

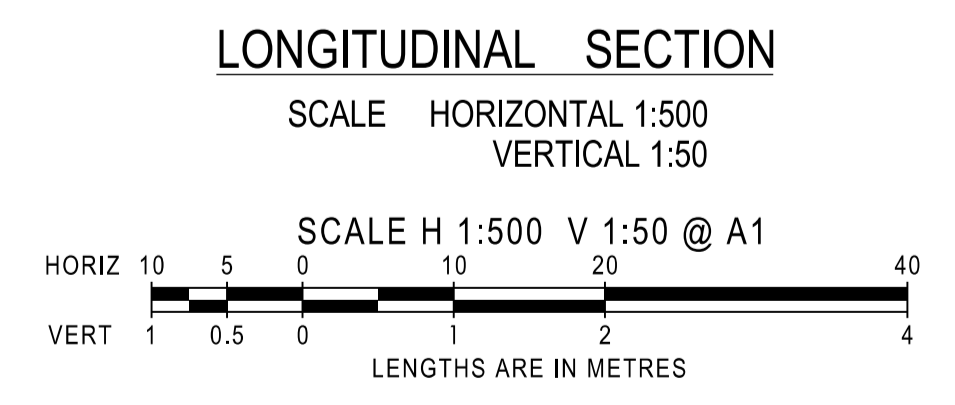

AMENDMENTS	VER	DATE	REMARKS	 <b>breese pitt dixon pty. ltd.</b> land surveyors civil engineers 1/19 cato street hawthorn east, 3123 telephone 8823 2300 fax no. 8823 2310
	MELWAY REF.	386-F-3		
	SURVEY	VERIS		
	DESIGN	R.W.		
<b>CLOVERTON ESTATE</b> <b>STAGE 328</b> <b>LONGITUDINAL SECTIONS</b>				MUNICIPALITY <b>HUME</b> REFERENCE <b>8460 E/328</b>
CHECKED A.K. SCALE AS SHOWN DATUM AHD DATE AUG'22 SHEET 3 OF 16 P1				FILE: E:\96\2022



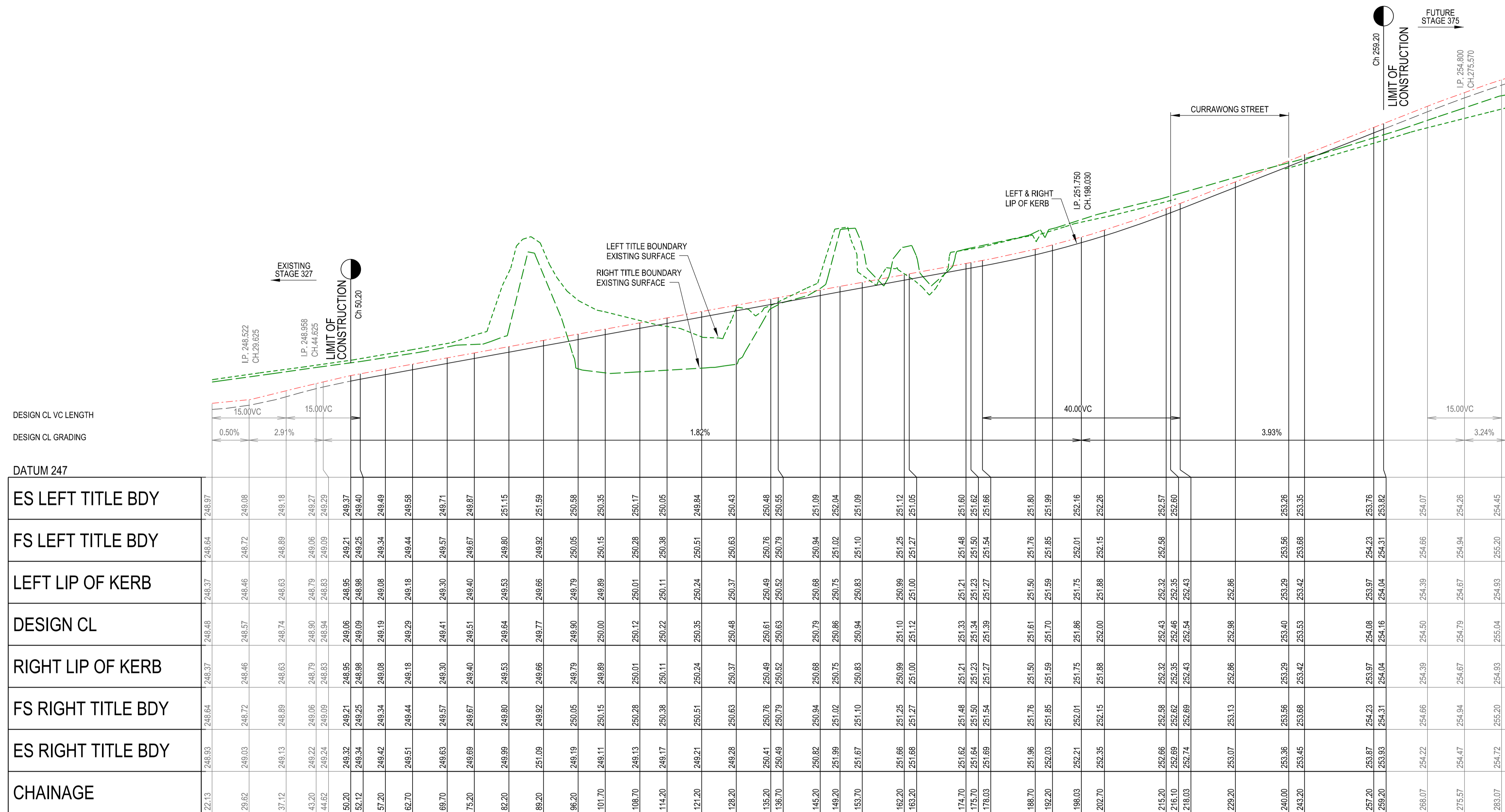

MAGNESIUM ROAD

LONGITUDINAL SECTION

SCALE HORIZONTAL 1:50  
VERTICAL 1:50

SCALE H 1:500 V 1:50 @ A1

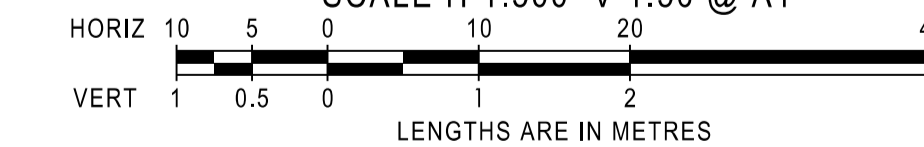

AMENDMENTS		<p>breese pitt dixon pty. ltd. land surveyors civil engineers</p>	MELWAY REF. 386-F-3	<p>CLOVERTON ESTATE STAGE 328 LONGITUDINAL SECTIONS</p>	MUNICIPALITY HUME		
VER	DATE		SURVEY VERIS		REFERENCE 8460 <sup>E</sup> /328		
			DESIGN R.W.				
			DRAWN D.W.				
		CHECKED A.K.	SCALE AS SHOWN	DATUM AHD	DATE AUG'22	SHEET 4 OF 16	P1

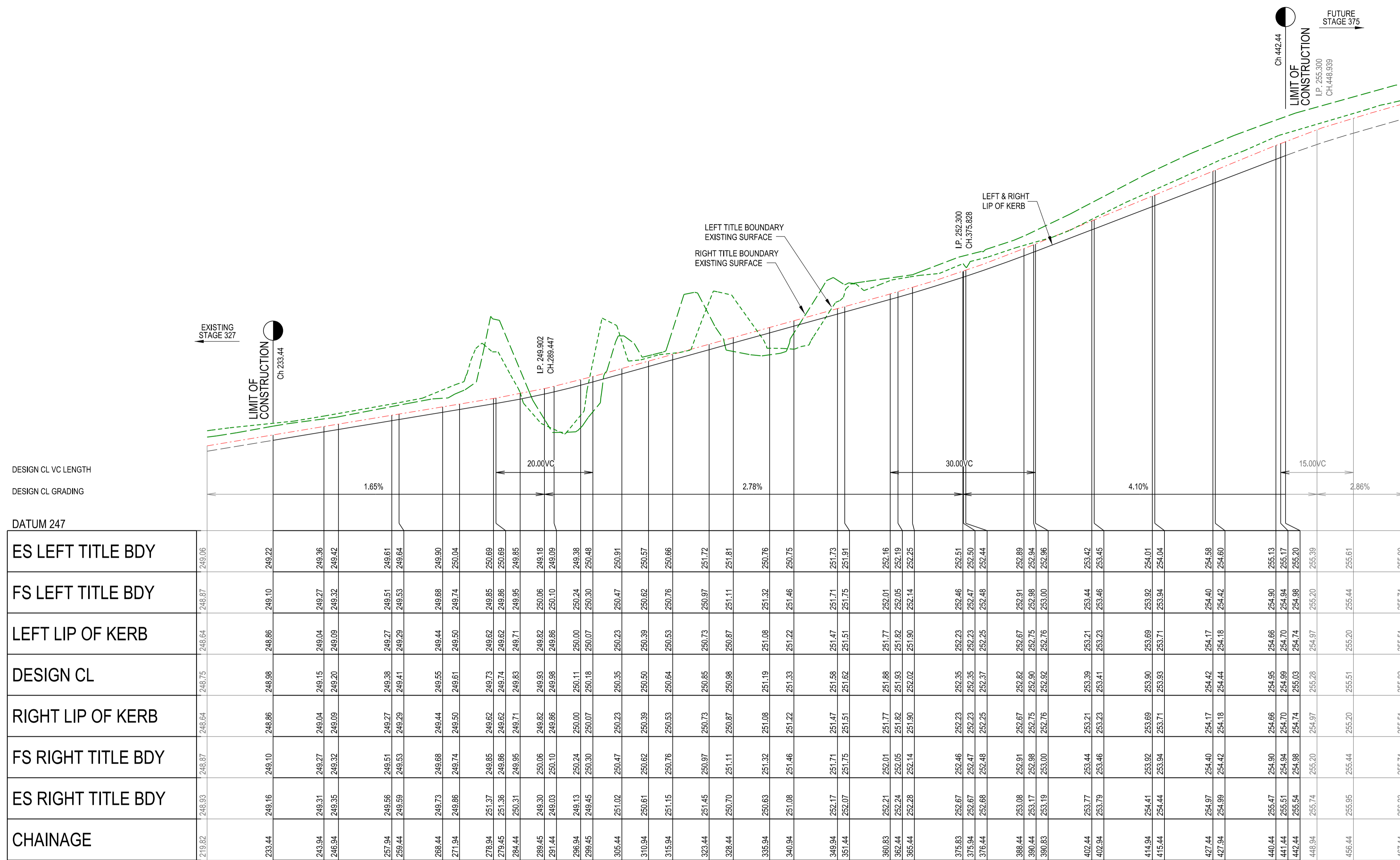

STILT STREET

LONGITUDINAL SECTION

SCALE HORIZONTAL 1:500  
VERTICAL 1:50

SCALE H 1:500 V 1:50 @ A1

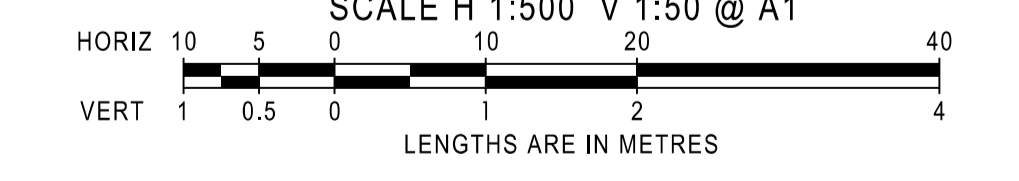

AMENDMENTS		 breese pitt dixon pty. ltd. land surveyors civil engineers		1/19 cato street hawthorn east, 3123 telephone 8823 2300 fax no. 8823 2310	
MELWAY REF.	386-F-3	<b>CLOVERTON ESTATE STAGE 328 LONGITUDINAL SECTIONS</b>		MUNICIPALITY	
SURVEY	VERIS			HUME	
DESIGN	R.W.			REFERENCE	
DRAWN	D.W.			8460 <sup>E</sup> /328	
VER	DATE	REMARKS	CHECKED	A.K.	SCALE AS SHOWN
					DATUM AHD
					DATE AUG'22
					SHEET 5 OF 16
					P1



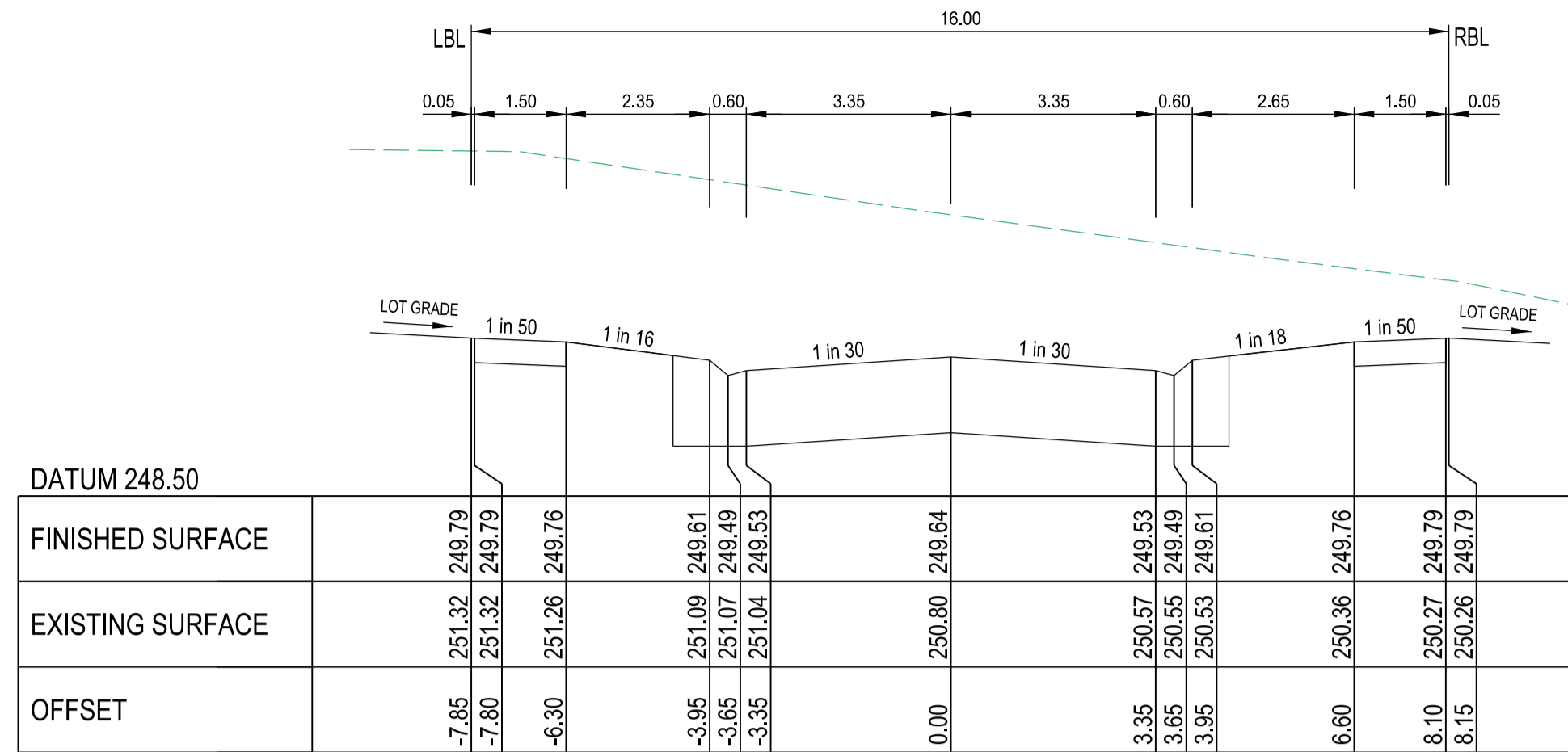

TITANIUM STREET Ch 68.20

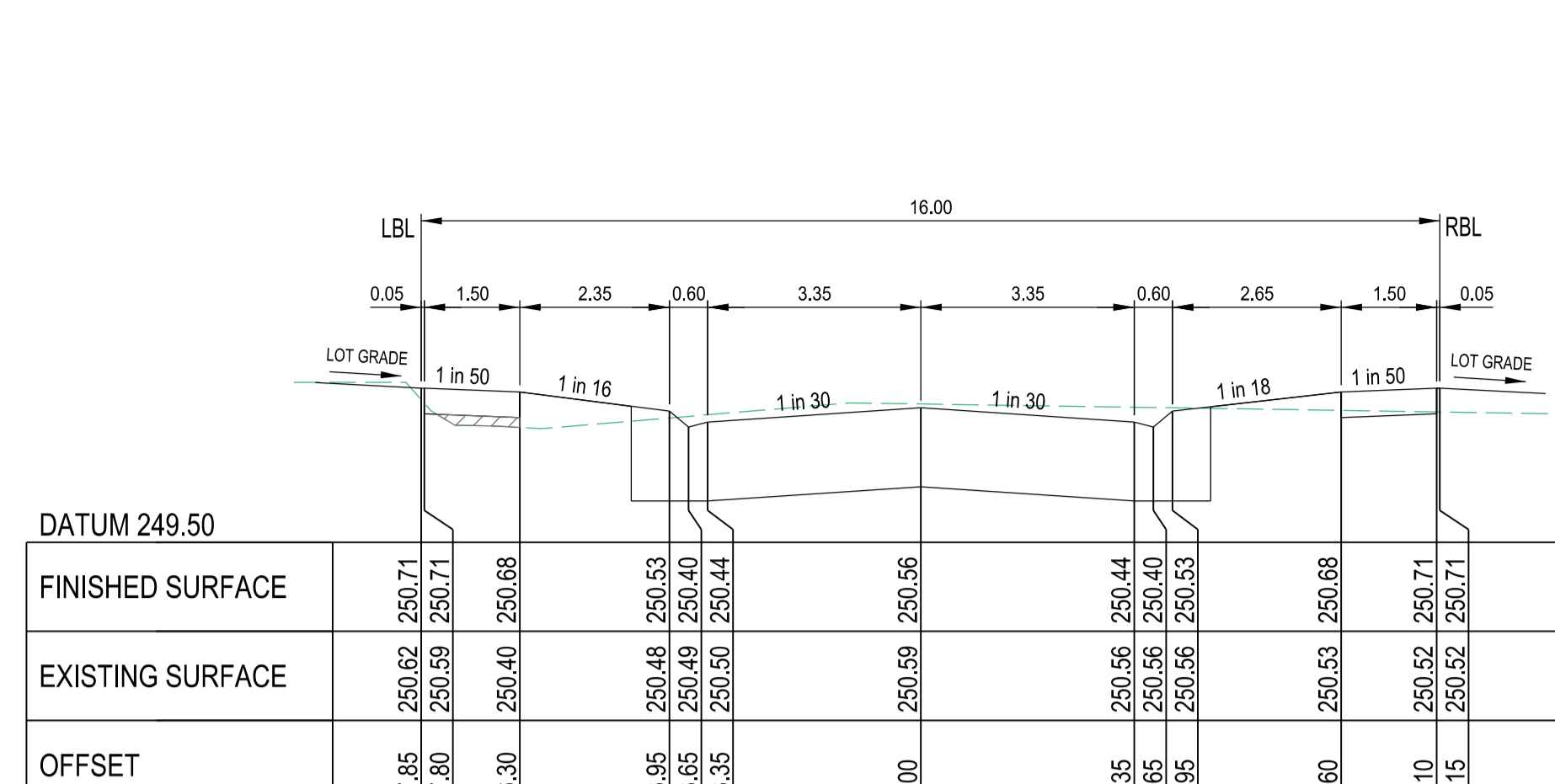

TITANIUM STREET Ch 119.70

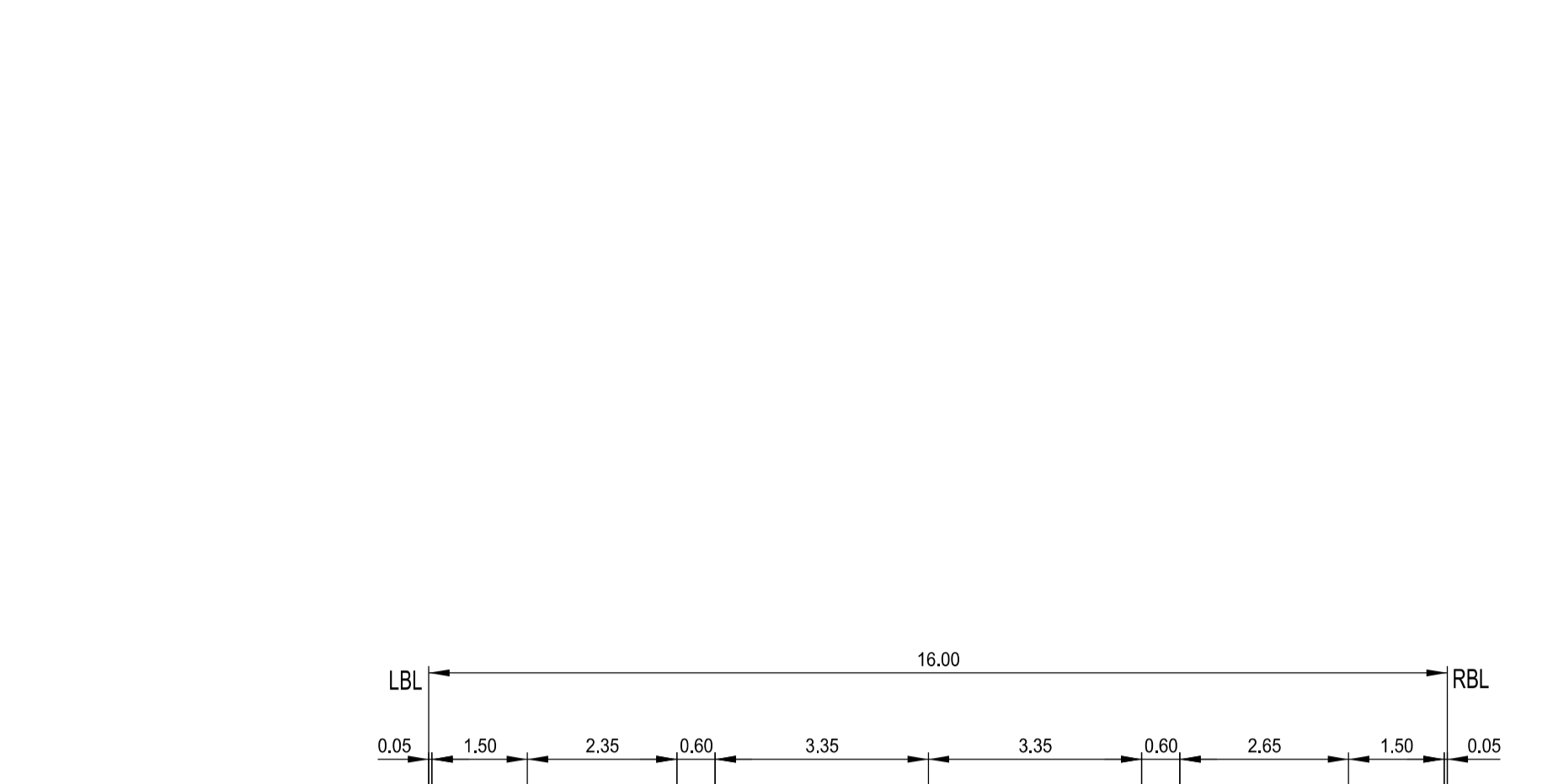

TITANIUM STREET Ch 216.10

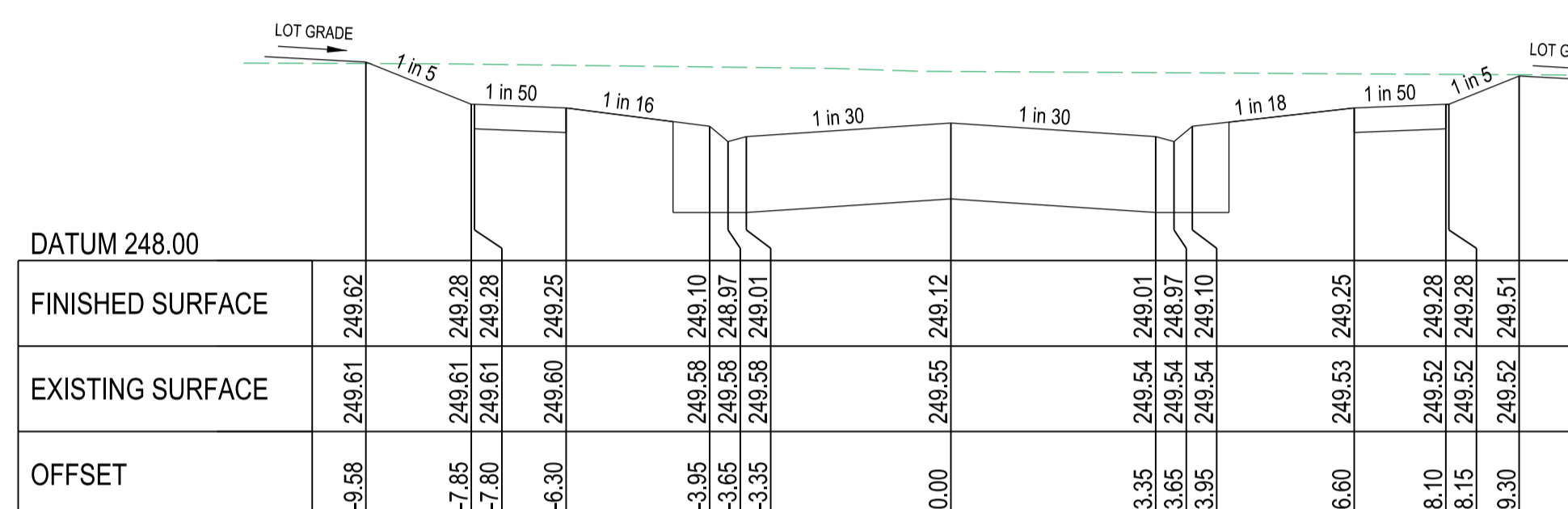

TITANIUM STREET Ch 46.20

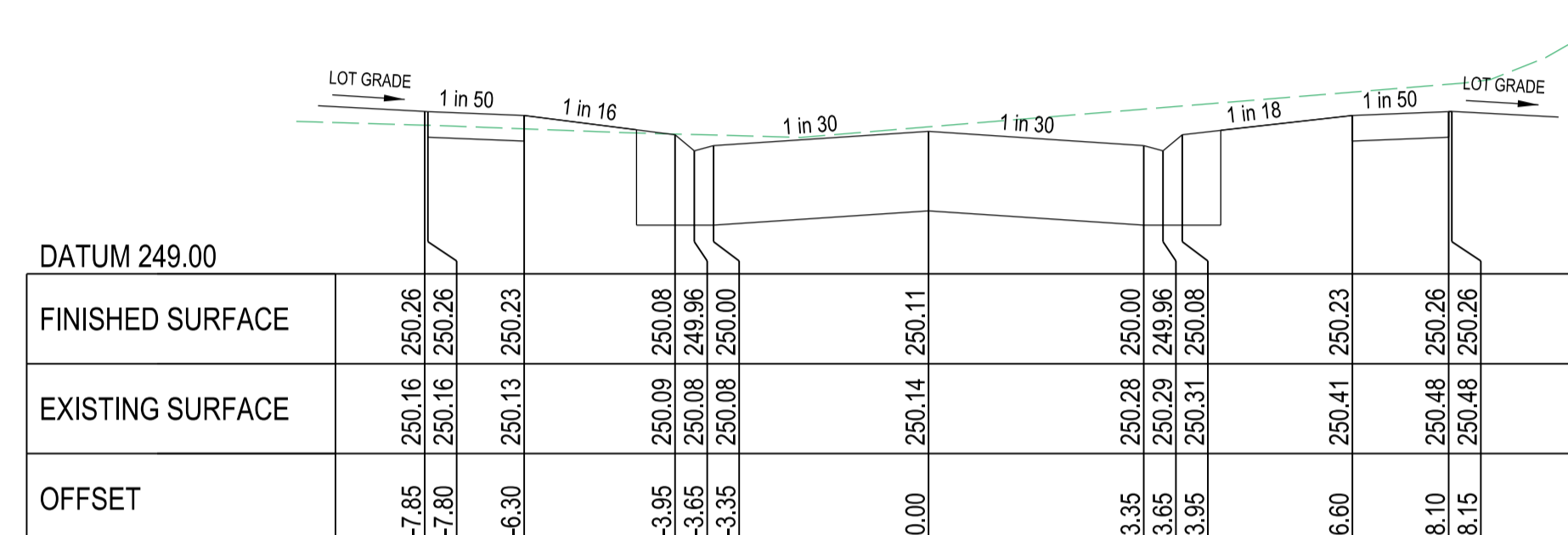

TITANIUM STREET Ch 94.70

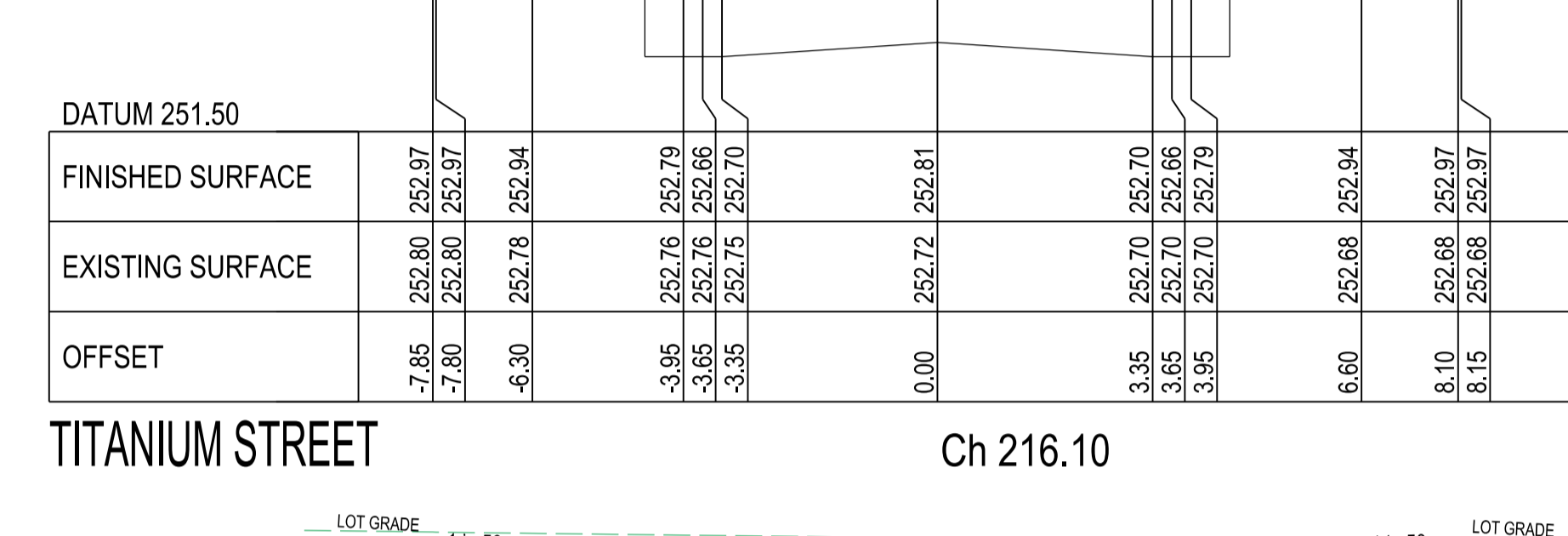

TITANIUM STREET Ch 192.20

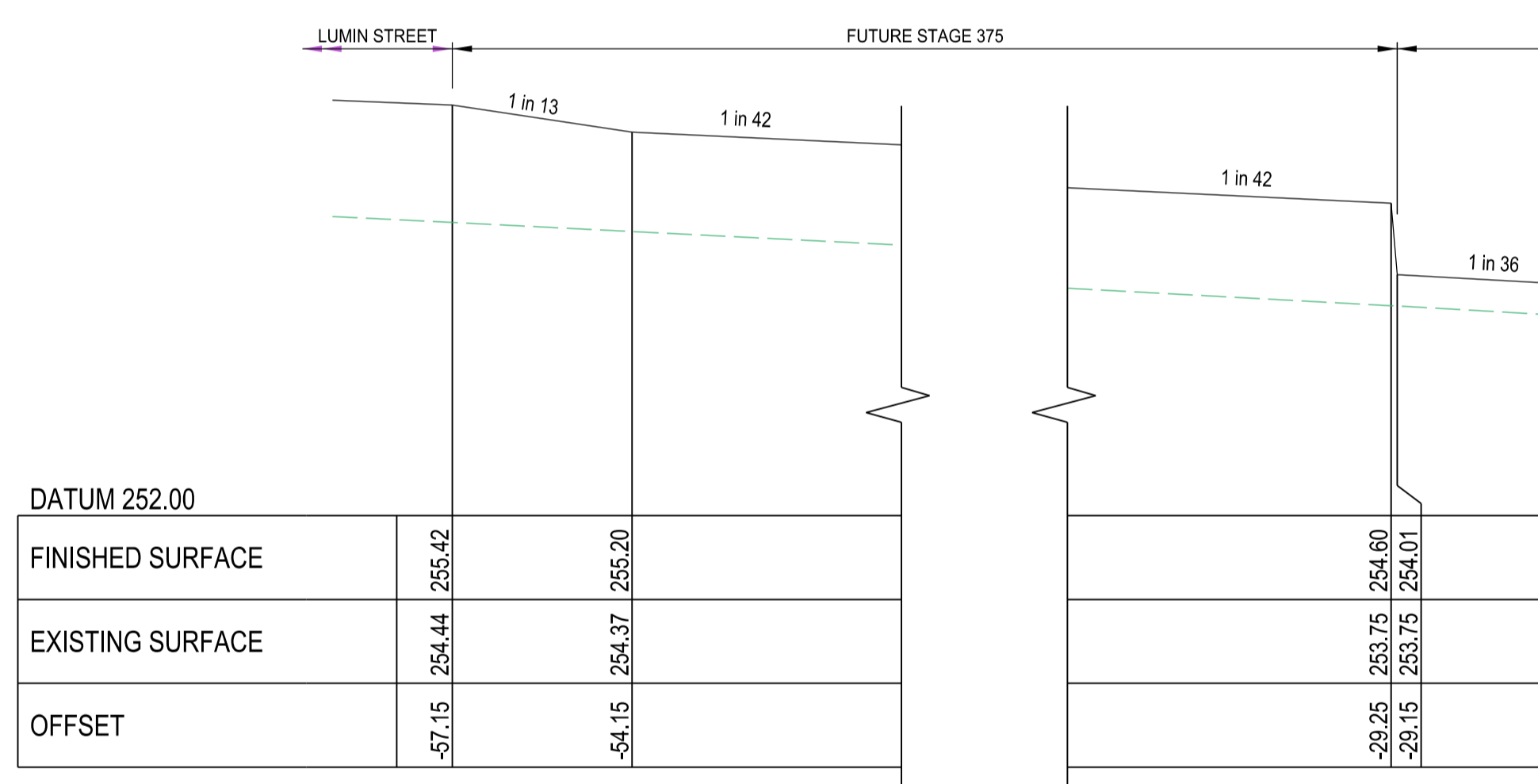

CURRAWONG STREET Ch 252.00

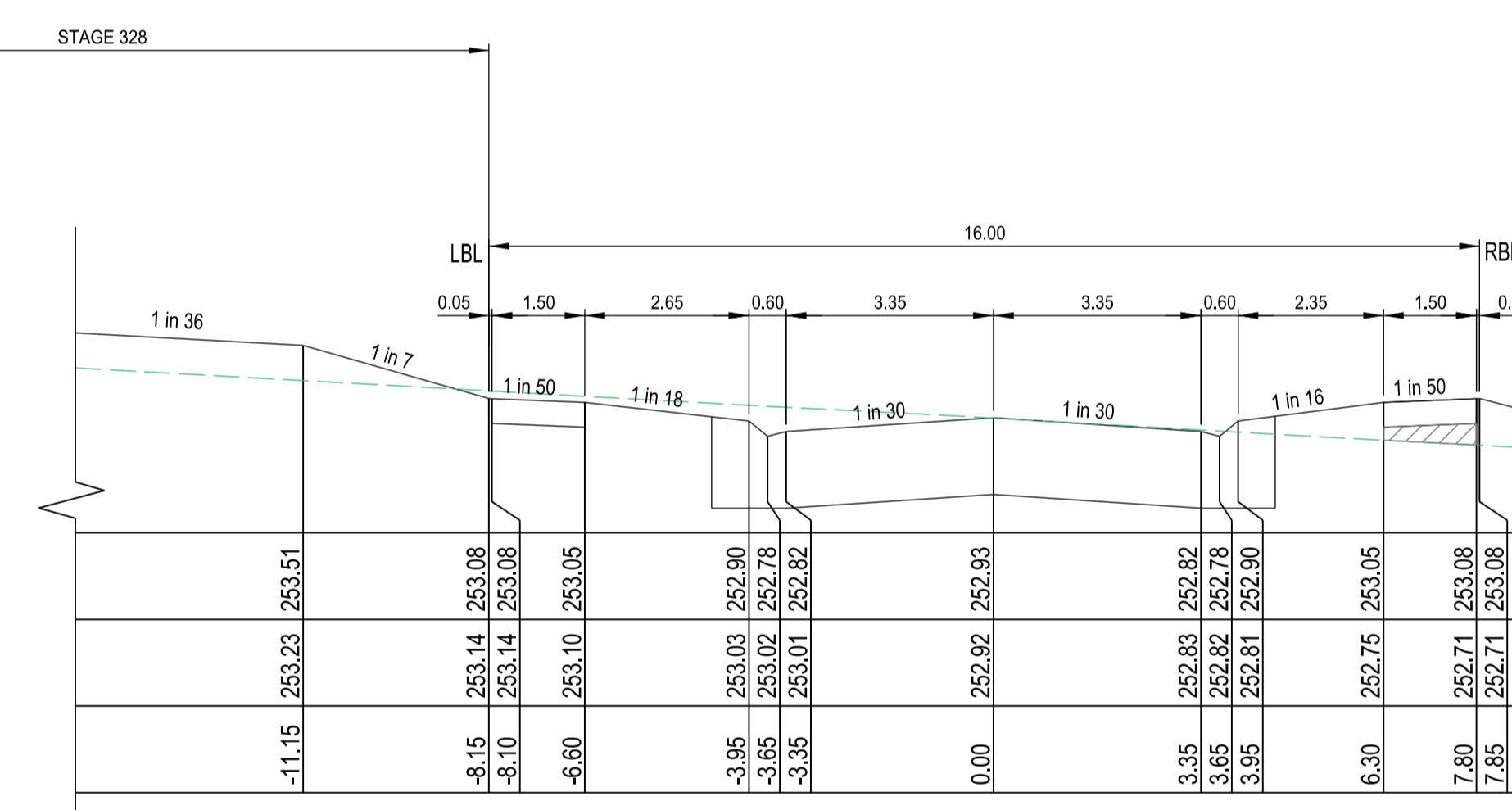

TITANIUM STREET Ch 141.90

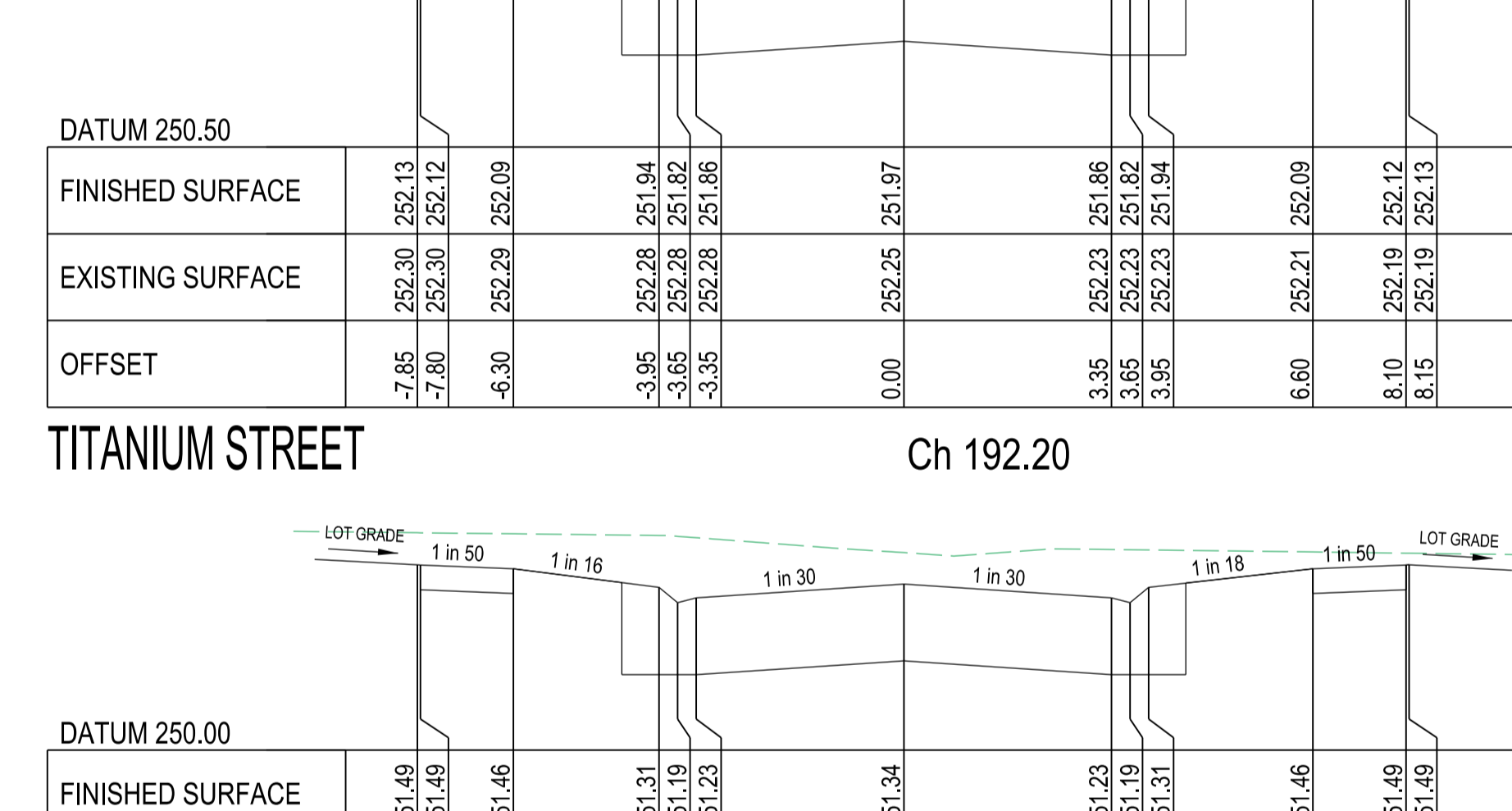

TITANIUM STREET Ch 163.70

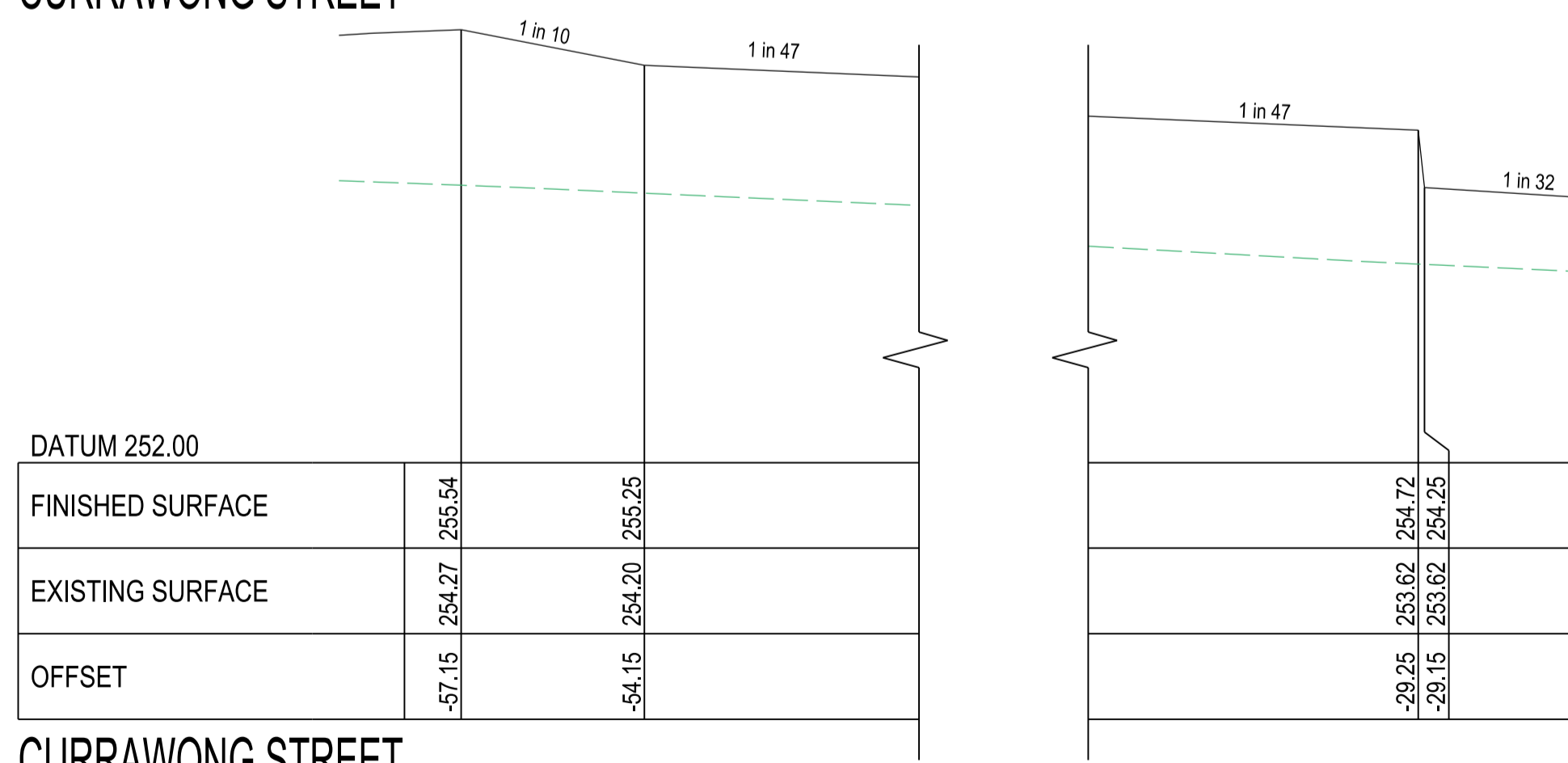

CURRAWONG STREET Ch 252.00

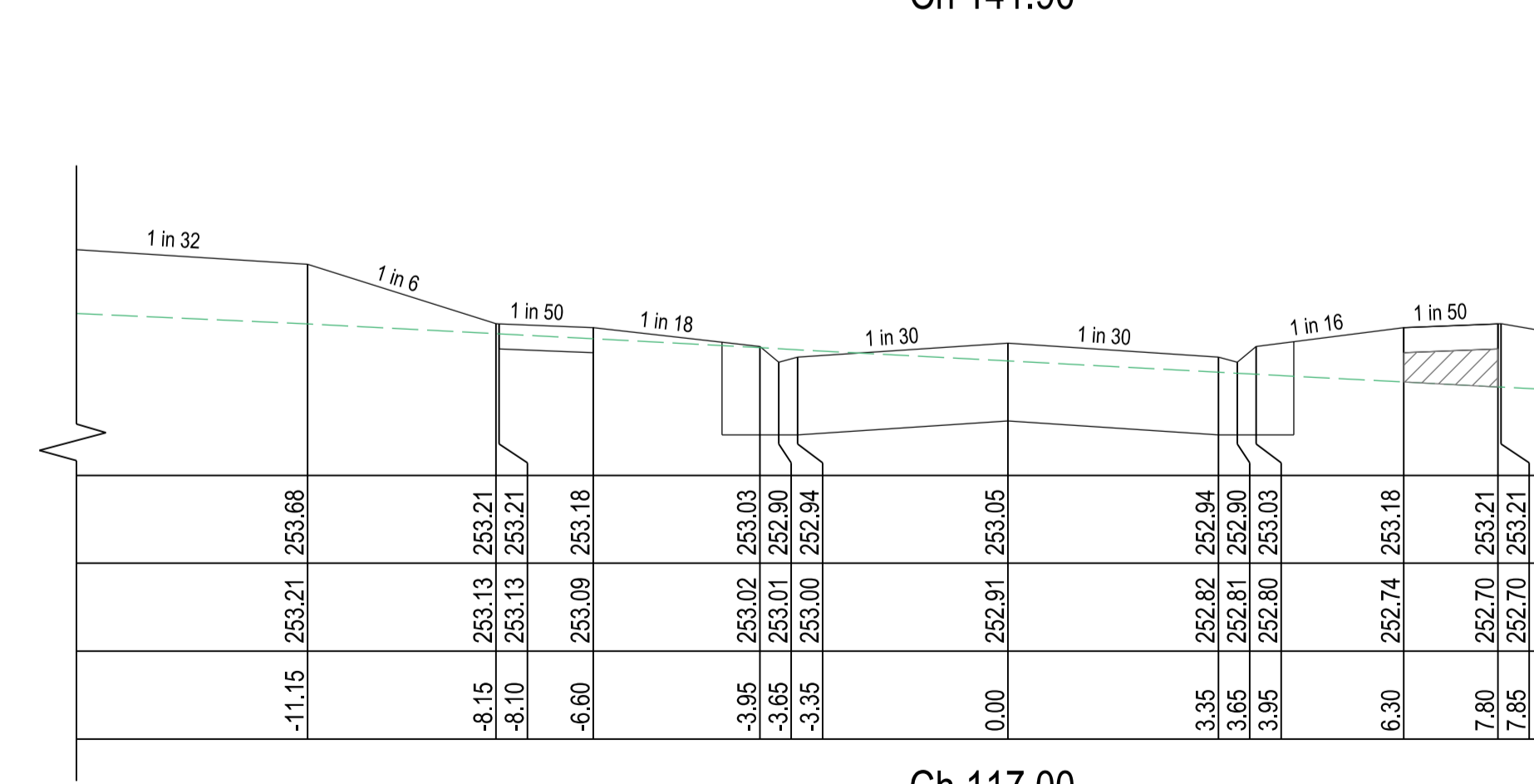

TITANIUM STREET Ch 117.00

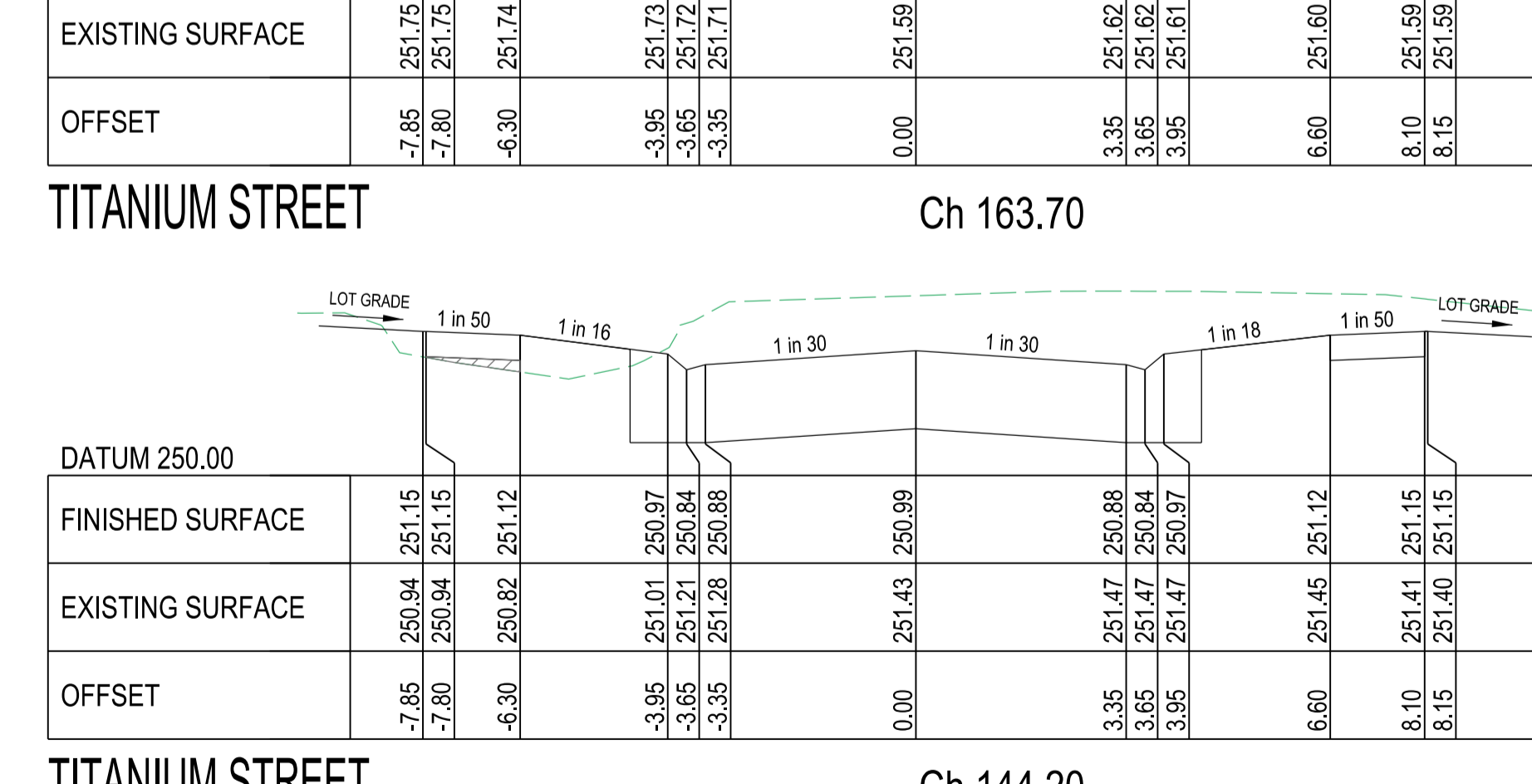

TITANIUM STREET Ch 144.20

**ALLOTMENT GRADE NOTE**  
 MINIMUM 1 IN 150 LOT GRADE INDICATED THUS: LOT GRADE

**ALLOTMENT BATTER NOTE**  
 IF NOT SHOWN FOR CLARITY ALL BATTERS WITHIN ALLOTMENTS TO BE GRADE 1 IN 5, UNLESS NOTED OTHERWISE

INDICATES CRUSHED ROCK BACKFILL

**CROSS SECTIONS**  
 SCALE HORIZONTAL 1:100  
 VERTICAL 1:50

SCALE H 1:100 V 1:50 @ A1

HORIZ 2 1 0 2 4 8  
 VERT 1 0.5 0 1 2 4

LENGTHS ARE IN METRES

AMENDMENTS		<b>breese pitt dixon pty. ltd.</b> land surveyors civil engineers		1/19 cato street hawthorn east, 3123 telephone 8823 2300 fax no. 8823 2310	
MELWAY REF.	386-F-3	<b>CLOVERTON ESTATE</b> <b>STAGE 328</b> <b>CROSS SECTIONS</b>		MUNICIPALITY	
SURVEY	VERIS			HUME	
DESIGN	R.W.			REFERENCE	
DRAWN	D.W.			8460 <sup>E</sup> /328	
CHECKED	A.K.	SCALE	AS SHOWN	DATUM	AHD
DATE		DATE	AUG '22	SHEET	6 OF 16
REMARKS					P1



HUME COUNCIL STANDARD NOTES:

- ALL WORKS TO BE CARRIED OUT IN ACCORDANCE WITH VPA AND HUME CITY COUNCIL STANDARD DRAWINGS, SPECIFICATIONS, APPROVED PLANS AND TO THE SATISFACTION OF THE CHIEF EXECUTIVE OFFICER AND/OR THEIR REPRESENTATIVE.
- COUNCIL TO BE NOTIFIED SEVEN (7) CLEAR WORKING DAYS PRIOR TO THE COMMENCEMENT OF WORKS WITH A PRECOMMENCEMENT MEETING BEING HELD BETWEEN HUME CITY COUNCIL, THE DEVELOPER'S CONSULTANT AND THE CONTRACTOR BEFORE WORKS COMMENCE. A SITE MANAGEMENT PLAN IS TO BE SUBMITTED PRIOR TO COMMENCEMENT OF WORKS AND PRIOR TO AN ONSITE PRECOMMENCEMENT MEETING.
- PRIOR TO COMMENCEMENT OF THE WORKS, THE CONTRACTOR SHALL PROVIDE THE FOLLOWING INFORMATION:
  - a) SOURCE OF QUARRY MATERIAL
  - b) N.A.T.A. APPROVED TEST RESULTS FOR THE F.C.R. THAT IS TO BE USED
  - c) IF THE SOURCE OF THE QUARRY MATERIAL IS CHANGED DURING THE COURSE OF THE WORKS, THEN NEW TEST RESULTS SHALL BE PROVIDED.
- PRIOR TO COMMENCEMENT OF WORKS ON SITE, THE CONTRACTOR MUST ENSURE THAT ALL MATTERS RELATING TO THE OCCUPATIONAL HEALTH AND SAFETY ACT 2004 AND OHS REGULATIONS 2007 HAVE BEEN AND WILL BE COMPLIED WITH.
- ON COMMENCEMENT OF CONSTRUCTION WORKS, THE CONTRACTOR MUST COMPLY WITH THE RECOMMENDATIONS OF THE ENVIRONMENT PROTECTION AUTHORITY PUBLICATION "CONSTRUCTION TECHNIQUES FOR SEDIMENT POLLUTION CONTROL" APPROPRIATE SILTATION CONTROL IS TO BE MAINTAINED THROUGHOUT THE CONSTRUCTION AND MAINTENANCE PERIOD OF THE WORKS.
- THE DISPOSAL SITE FOR SPOIL REMOVAL FROM SITE AND TRUCK ROUTE IS TO BE SUBMITTED TO AND APPROVED BY THE CHIEF EXECUTIVE OFFICER AND/OR THEIR REPRESENTATIVE IN WRITING PRIOR TO THE COMMENCEMENT OF ANY WORKS.

- WHERE WORKS ARE IN THE VICINITY OF EXISTING SERVICES, THESE SERVICES ARE TO BE LOCATED AND EXPOSED/PROVED PRIOR TO COMMENCEMENT OF WORKS, AND THE RELEVANT AUTHORITIES NOTIFIED SEVEN (7) CLEAR DAYS PRIOR TO THE COMMENCEMENT OF THE WORKS.
- ALL DIMENSIONS ARE IN METRES UNLESS NOTED OTHERWISE.
- ALL LEVELS ARE TO AUSTRALIAN HEIGHT DATUM (AHD).
- ALL CO-ORDINATES ARE TO MAP GRID OF AUSTRALIA (MGA).
- THE CONTRACTOR MUST ARRANGE THE REQUISITE INSPECTIONS OF THE WORKS WITH THE CHIEF EXECUTIVE OFFICER AND/OR THEIR REPRESENTATIVE AS PER THE HOLD POINTS IN THE VPA MANUAL AND HUME CITY COUNCIL SPECIFICATIONS
- FILL AREAS TO BE STRIPPED OF TOPSOIL, FILLED AND TOPSOIL REPLACED TO OBTAIN FINAL FILL LEVELS AS SHOWN ON PLAN. FILLING IS TO BE CLEAN CLAY COMPACTED TO A DENSITY NOT LESS THAN 95% OF THE MAXIMUM DRY DENSITY VALUE DETERMINED BY THE STANDARD COMPACTION TEST IN ACCORDANCE WITH A.S.1289.5.1.1-2003.
- FILLING TO COMPLY WITH A.S.3798-2007, LEVEL 1 UNLESS SPECIFIED OTHERWISE.
- THE CONTRACTOR IS RESPONSIBLE FOR ENSURING THAT ALL IMPORTED FILL MATERIAL, INCLUDING TOPSOIL, SATISFIES THE DESCRIPTION FOR CLEAN FILL MATERIAL IN EPA BULLETIN PUBLICATION NO 448 (SEPT '95) AND SUBSEQUENT REVISIONS. THE CONTRACTOR SHALL IF REQUIRED PROVIDE VERIFICATION INCLUDING TEST CERTIFICATES TO THE CHIEF EXECUTIVE OFFICER AND/OR THEIR REPRESENTATIVE.
- WHERE, AS A CONDITION OF THE PLANNING PERMIT OR AS A RESULT OF THE PRE-CONSTRUCTION MEETING, FENCING OF AREAS CONTAINING TREES, NATIVE GRASSES AND SHRUBS IS REQUIRED, A THREE STRAND STAR PICKET AND WIRE FENCE SHALL BE CONSTRUCTED.
- NO TREE OR NATIVE VEGETATION IS TO BE DISTURBED OR REMOVED WITHOUT PRIOR APPROVAL FROM COUNCIL'S SUSTAINABLE ENVIRONMENT DEPARTMENT. ANY TREES REMOVED, VEGETATION OR OTHER MATERIALS ARE NOT TO BE BURNT ON SITE.

- BEFORE COMMENCING WORK ON TRENCHES IN EXCESS OF 1.5M DEEP, NOTICE OF SUCH PROPOSAL IS TO BE FORWARDED BY THE CONTRACTOR TO WORKSAFE VICTORIA.
- THE CONTRACTOR IS TO OBTAIN A BUILDING PERMIT FOR ANY STRUCTURES/FENCES AND FOR ANY RETAINING WALLS OVER 1.0M IN HEIGHT.
- ANY INFRASTRUCTURE DAMAGE DURING THE DEFECTS LIABILITY PERIOD IS THE RESPONSIBILITY OF THE DEVELOPER OR HIS REPRESENTATIVE AND IS TO BE REINSTATED TO THE SATISFACTION OF THE CHIEF EXECUTIVE OFFICER OR HIS REPRESENTATIVE.
- PRIOR TO STATEMENT OF COMPLIANCE ALL DISTURBED AREAS (INCLUDING NATURESTRIPS, BATTERS, ALLOTMENTS WITH GRADES OF 1:5 AND GREATER, AND RESERVES) ARE TO BE REINSTATED TO A CLEAN, TIDY CONDITION, TOP DRESSED (100mm LOAMY TOP SOIL FREE OF RUBBISH, DEBRIS, CLUMPS, SODS AND CLAY LUMPS) LIGHTLY COMPACTED AND HYDRO MULCHED. HYDROMULCH AND SEED MIX TO BE:
  - 40KG/HA KIKUYU
  - 200KG/HA TURF TYPE PERENNIAL RYE.
  - 100KG/HA FINE LEAF FESCUE.
  - 1500KG/HA OF CELLULOSE FIBRE
  - SOIL BINDER, SPECIFICALLY MANUFACTURED FOR HYDROMULCHING, USED AT MANUFACTURERS RECOMMENDED RATES. (E.G. ORGANIC GAUR TACKFIRES @ 20-30 KG/HA, BASED ON, SITE CONDITIONS)
- GRASS IS TO BE ESTABLISHED PRIOR TO THE END OF THE MAINTENANCE PERIOD, UNLESS OTHERWISE AGREED IN WRITING.
- FOOTPATHS ARE TO BE 50mm OFFSET FROM TITLE BOUNDARIES UNLESS NOTED OTHERWISE. VEHICLE CROSSING ALIGNMENTS ARE GENERALLY TO BE PARALLEL TO THE SIDE BOUNDARY.
- ALL NEW CONCRETE WORKS SHALL BE JOINED INTO ABUTTING EXISTING CONCRETE WITH 450mm LONG Y20 DOWEL BARS @ 600 CENTRES, UNLESS OTHERWISE SPECIFIED.
- ANY EXPOSED AGGREGATE CONCRETE WORKS TO BE ACHIEVED BY SAND-BLASTING ONLY. WASHING AGGREGATE OFF WITH WATER IS NOT PERMITTED.

- SERVICE CONDUITS TRENCHES UNDER ROAD PAVEMENTS ARE TO BE BACKFILLED WITH 20mm 3% CEMENT TREATED CLASS 3 CRUSHED ROCK COMPACTED TO A DENSITY NOT LESS THAN 95% OF THE MAXIMUM DRY DENSITY VALUE DETERMINED BY THE MODIFIED COMPACTION TEST IN ACCORDANCE WITH A.S.1289.5.2.1-2003. ALL SERVICE CONDUITS TRENCHES UNDER FOOTPATH, VEHICULAR CROSSINGS, PARKING BAYS AND WITHIN 750MM OF PARKING BAYS TO BE BACKFILLED WITH CLASS 3 CRUSHED ROCK.
- ALL STORMWATER DRAINS TO BE CLASS 2 R.C. OR RIGID F.R.C. PIPES WITH ADCOL FLEXIBLE COLLARS UNLESS NOTED OTHERWISE. ALL PIPES UP TO & INCLUDING 750mm DIA. ARE TO BE RUBBER RING JOINTED. INTERLOCKING/FLUSH JOINTS WITH EXTERNAL BANDS CAN ONLY BE USED ON PIPE SIZES OVER 750mm DIA.
- WHERE NEW ASPHALT, CONCRETE K & C, PATHS AND DRIVEWAYS MATCH INTO EXISTING, THE EXISTING SURFACE IS TO BE SAW CUT AND MATCHED NEATLY.
- ALL REDUNDANT ASSETS ARE TO BE REMOVED AND DISPOSED OFF SITE.
- ALL TREES AND SHRUBS ARE TO BE RETAINED UNLESS OTHERWISE SHOWN OR DIRECTED BY THE CHIEF EXECUTIVE OFFICER AND/OR THEIR REPRESENTATIVE.
- AT THE COMPLETION OF ALL WORKS, ALL RUBBISH, DEBRIS AND SURPLUS SPOIL SHALL BE REMOVED AND THE SITE SHALL BE CLEARED TO THE SATISFACTION OF THE CHIEF EXECUTIVE OFFICER AND/OR THEIR REPRESENTATIVE.
- ALL DRAINS BEHIND KERB AND CHANNEL SHALL BE BACKFILLED TO MATCH PAVEMENT SUBGRADE LEVEL WITH 20mm CLASS 3 F.C.R. COMPACTED TO 95% OF THE MAXIMUM DRY DENSITY VALUE DETERMINED BY THE MODIFIED COMPACTION TEST IN ACCORDANCE WITH A.S.1289.5.2.1-2003. ALL DRAINS, SEWERS, GAS & WATER MAINS LAID THROUGH THE ROAD PAVEMENT (EXCEPT CONDUITS) ARE TO BE BACKFILLED WITH 20mm CLASS 2 F.C.R. COMPACTED TO 98% OF THE MAXIMUM DRY DENSITY VALUE DETERMINED BY THE MODIFIED COMPACTION TEST IN ACCORDANCE WITH A.S.1289.5.2.1-2003.
- PAVEMENT DEPTH SPECIFIED IS A MINIMUM DEPTH AND MAY BE VARIED BY THE CHIEF EXECUTIVE OFFICER AND/OR THEIR REPRESENTATIVE. SOFT SPOTS SHALL BE EXCAVATED TO A PROOF ROLLED BASE AND BACKFILLED WITH APPROVED MATERIAL COMPACTED IN 150mm LAYERS TO ACHIEVE TO A DENSITY NOT LESS THAN 95% OF THE MAXIMUM DRY DENSITY VALUE DETERMINED BY THE STANDARD COMPACTION TEST IN ACCORDANCE WITH A.S.1289.5.1.1-2003.

HUME COUNCIL STANDARD NOTES:

- ALL EXISTING ASSETS AFFECTED BY THE WORKS; EG SIGNS, VEHICLE CROSSINGS, FOOTPATHS, KERB AND LINEMARKING SHALL BE REINSTATED BY THE CONTRACTOR PRIOR TO THE COMPLETION OF THE WORKS TO THE SATISFACTION OF THE CHIEF EXECUTIVE OFFICER AND/OR THEIR REPRESENTATIVE.
- PRIOR TO THE COMPLETION OF THE WORKS ALL FIRE HYDRANTS ARE TO BE MARKED IN ACCORDANCE WITH "IDENTIFICATION OF STREET HYDRANTS FOR FIREFIGHTING PURPOSES" PUBLICATION (DEVELOPED BY C.F.A., M.F.B. & E.S.B). MARKINGS TO BE VIA BLUE PAVEMENT MARKER AND A (RED TOPPED) WHITE POST.
- AGRICULTURAL DRAINS ARE TO BE PLACED BEHIND ALL KERB AND CHANNEL, KERB ONLY AND EDGE STRIPS IN ACCORDANCE WITH EDM STANDARD DRAWING 202.
- ALL TABLE DRAINS AND VERGES ARE TO BE REINSTATED UPON COMPLETION OF WORKS TO THE SATISFACTION OF THE CHIEF EXECUTIVE OFFICER AND/OR THEIR REPRESENTATIVE.
- ALL TRAFFIC CONTROL MEASURES, SIGNS AND LINEMARKING SHALL BE IN ACCORDANCE WITH A.S.1742 - 1, 2 & 3. STREET NAME SIGNS ARE TO BE IN ACCORDANCE WITH STANDARD DRAWING 5D408.
- ALL LINEMARKING PAINT SHALL BE LONG LIFE TYPE IN ACCORDANCE WITH SECTION 95C OF THE HUME CITY COUNCIL SPECIFICATIONS. LATERAL WORKS AND ARROWS BEING COLD APPLIED PLASTIC TROWELLED INTO PLACE (MATERIAL DEGADUR PLASTELINE) AND LONGITUDINAL LINES BEING EXTRUDED THERMOPLASTIC MATERIAL.
- ALL SIGNS TO BE CLASS 1 HIGH INTENSITY TYPE AND TO COMPLY WITH THE REQUIREMENTS OF A.S.1743-2001.
- HOUSE DRAIN CONNECTIONS TO 150mm DIAMETER PIPES TO BE VIA A MANUFACTURED JUNCTION PIECE. 150mm DIAMETER STORMWATER PIPES ARE TO BE HEAVY DUTY SEWER GRADE. PVC PIPES SHALL BE BACKFILLED WITH 10mm MINUS F.C.R. TO 150mm ABOVE TOP OF PIPE IN ALL LOCATIONS.
- 100mm HOUSE DRAIN CONNECTIONS TO BE LAID AT AN OFFSET OF 5.5m FROM THE LOW SIDE OF TITLE BOUNDARY ROAD FRONTAGE AND PROPERTY INLETS 1.0m FROM THE LOW SIDE OF TITLE BOUNDARY REAR EASEMENTS UNLESS OTHERWISE SHOWN.
- BLASTING GENERALLY IS NOT ENCOURAGED, HOWEVER, BLASTING MAY BE REQUIRED AS A LAST RESORT DEPENDING ON GROUND CONDITIONS. COUNCIL IS TO BE NOTIFIED IN WRITING IF ANY BLASTING IS NECESSARY. RESIDENTS LIKELY TO BE AFFECTED BY THE BLASTING AND ALL SERVICE AUTHORITIES SHALL BE NOTIFIED IN WRITING PRIOR TO WORKS COMMENCING. COPIES OF THESE NOTIFICATIONS ARE TO BE SUBMITTED TO COUNCIL. RESIDENT NOTIFICATION LETTER IS TO INCLUDE BLASTING GUIDELINES, FIRING AND MISFIRE PROCEDURES AND CONTRACTOR AND CONSULTANT CONTACT NAMES AND PHONE NUMBERS. ALL BLASTING IS TO BE WITHIN THE LIMITS FOR AIR AND GROUND VIBRATION LEVELS AS SET DOWN IN A.S.2187.2-1993 ALL BLASTS SHALL BE MONITORED FOR AIR AND NOISE VIBRATION AT POTENTIALLY AFFECTED RESIDENCES. "FORM A" FROM AS2187.2-1993, AND WAVE TRACE COPIES ARE TO BE SUBMITTED TO COUNCIL FOR EACH BLAST. BLASTING IS TO BE RESTRICTED TO BETWEEN 9:00am AND 3:30pm. BLASTING IS NOT TO OCCUR ON WEEKENDS OR PUBLIC HOLIDAYS. BLASTING AREA SIGNS ARE TO BE PLACED AT ALL ENTRANCES TO THE SITE.
- FENCING TO BE PROVIDED ALONG LOT BOUNDARIES ABUTTING RESERVES TO THE SATISFACTION OF THE RESPONSIBLE AUTHORITY.
- WHERE SODIC SOILS ARE ENCOUNTERED, SODIC SOIL INVESTIGATIONS SHOULD BE CARRIED OUT BY A QUALIFIED SOIL SCIENTIST AND THE RECOMMENDATIONS OF THE REPORT SHOULD BE APPLIED DURING ROAD & DRAINAGE DESIGN AND CONSTRUCTION.

DATUM 252.00

FINISHED SURFACE	255.41	255.31
EXISTING SURFACE	254.23	254.17
OFFSET	-57.15	-54.15

CURRAWONG STREET

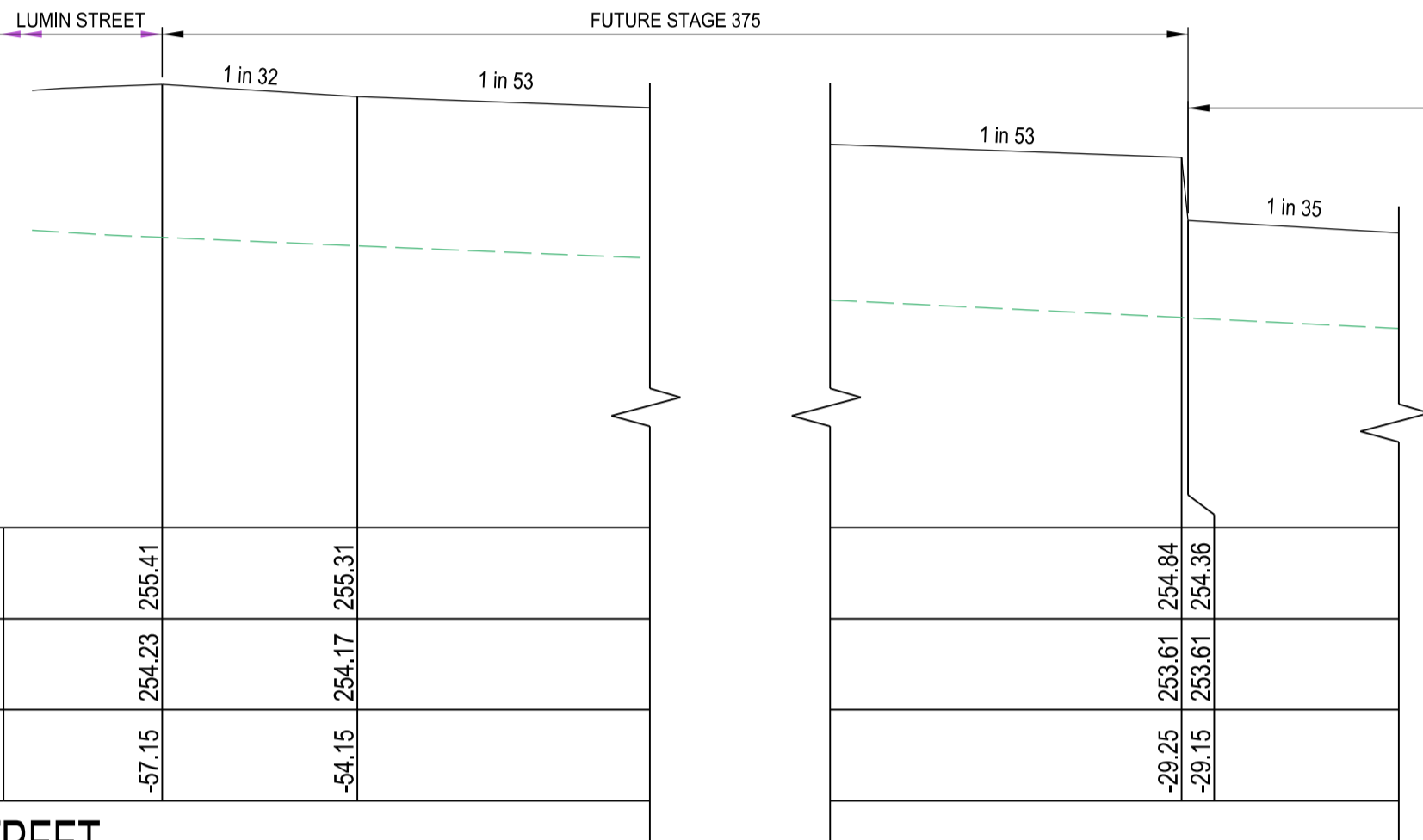

DATUM 252.50

FINISHED SURFACE	255.29	255.37
EXISTING SURFACE	254.38	254.29
OFFSET	-57.15	-54.15

CURRAWONG STREET

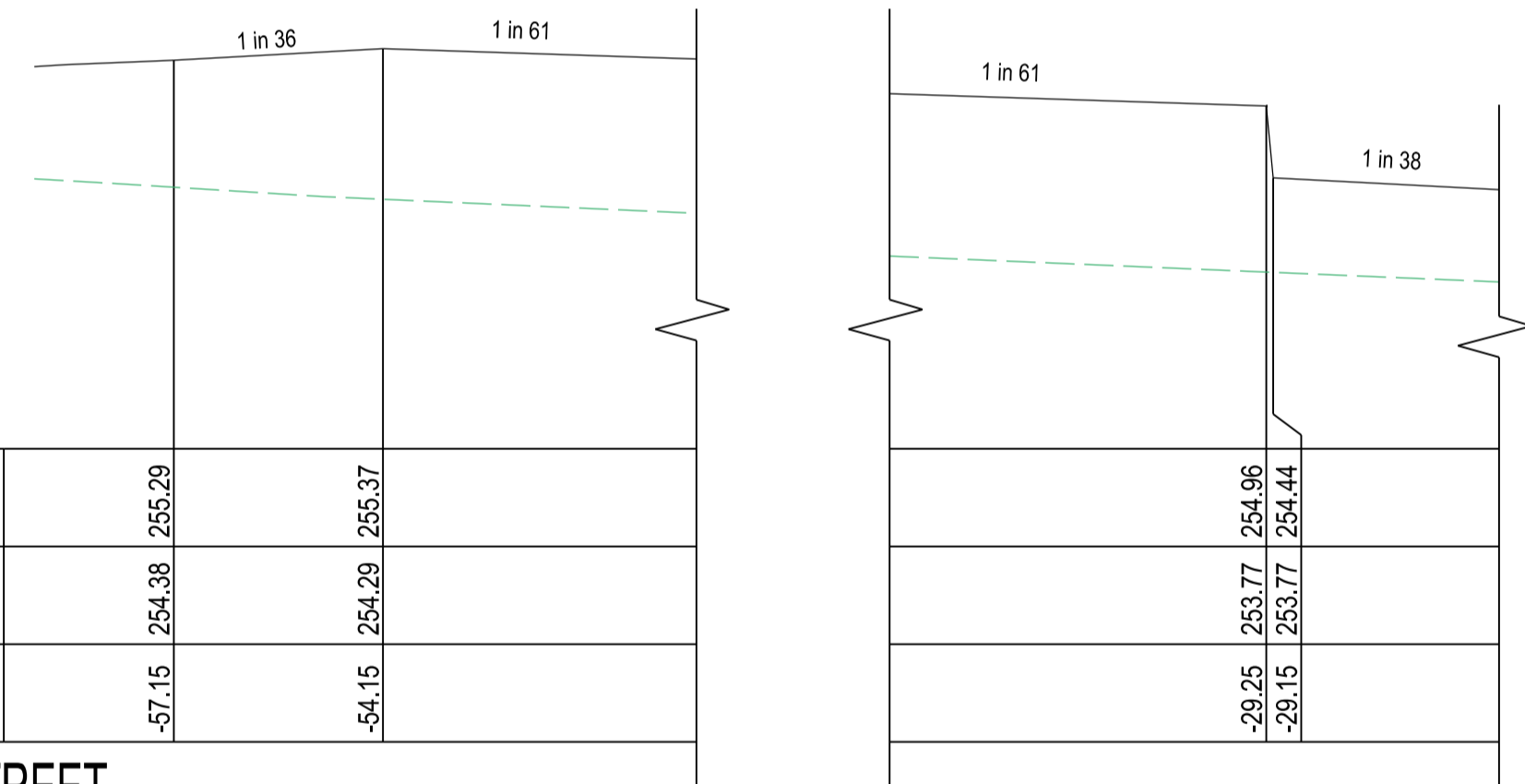

DATUM 252.50

FINISHED SURFACE	255.14	255.22
EXISTING SURFACE	254.71	254.63
OFFSET	-57.15	-54.15

CURRAWONG STREET

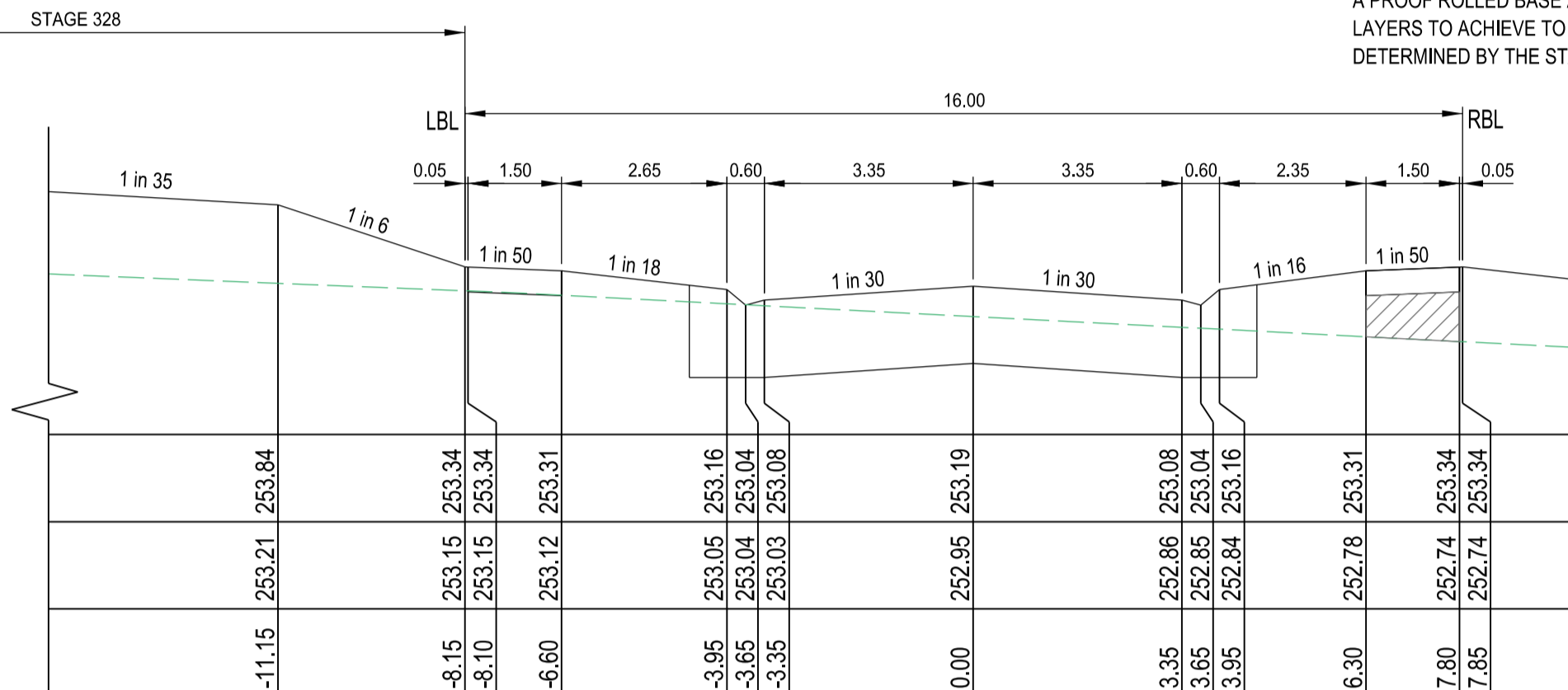
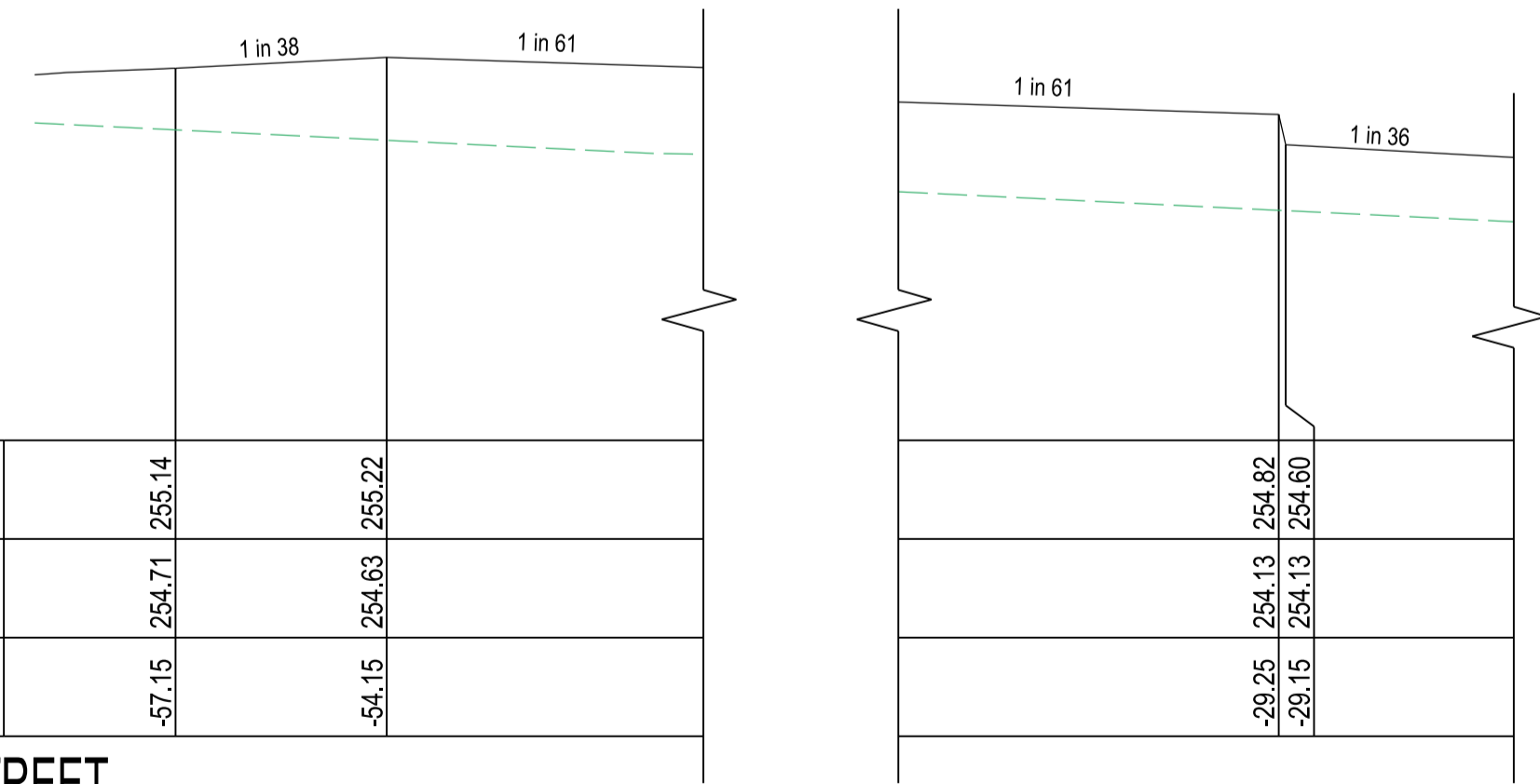

Ch 89.80

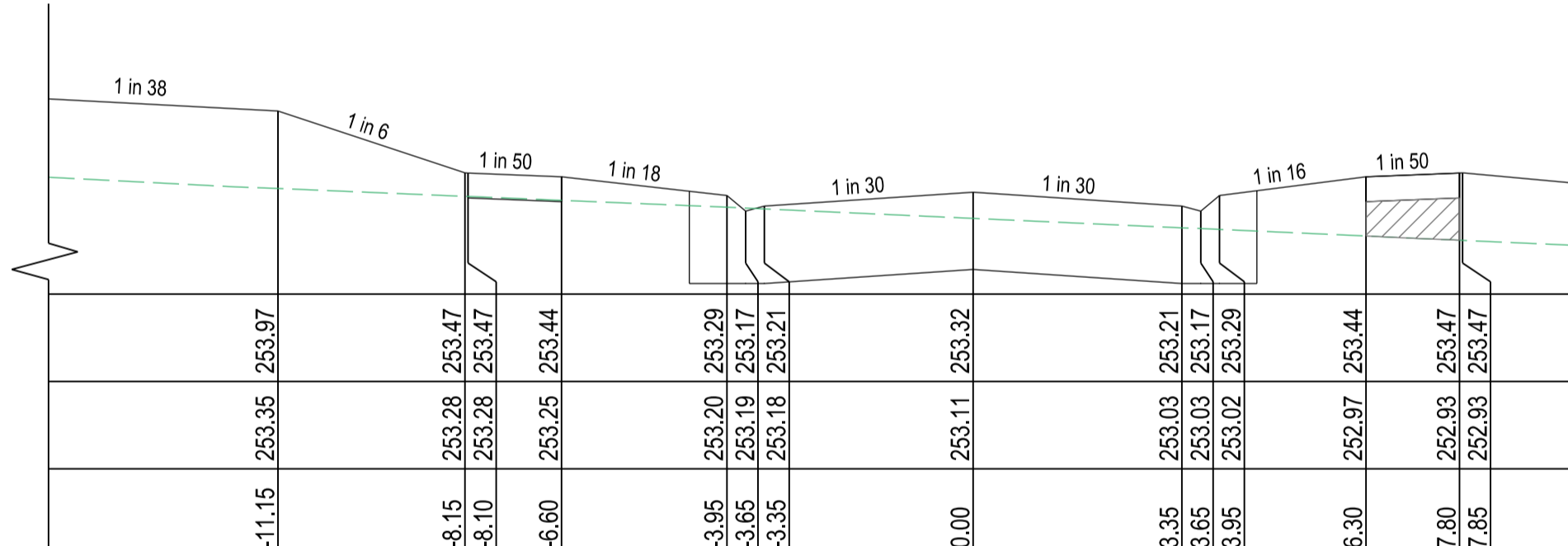

Ch 65.90

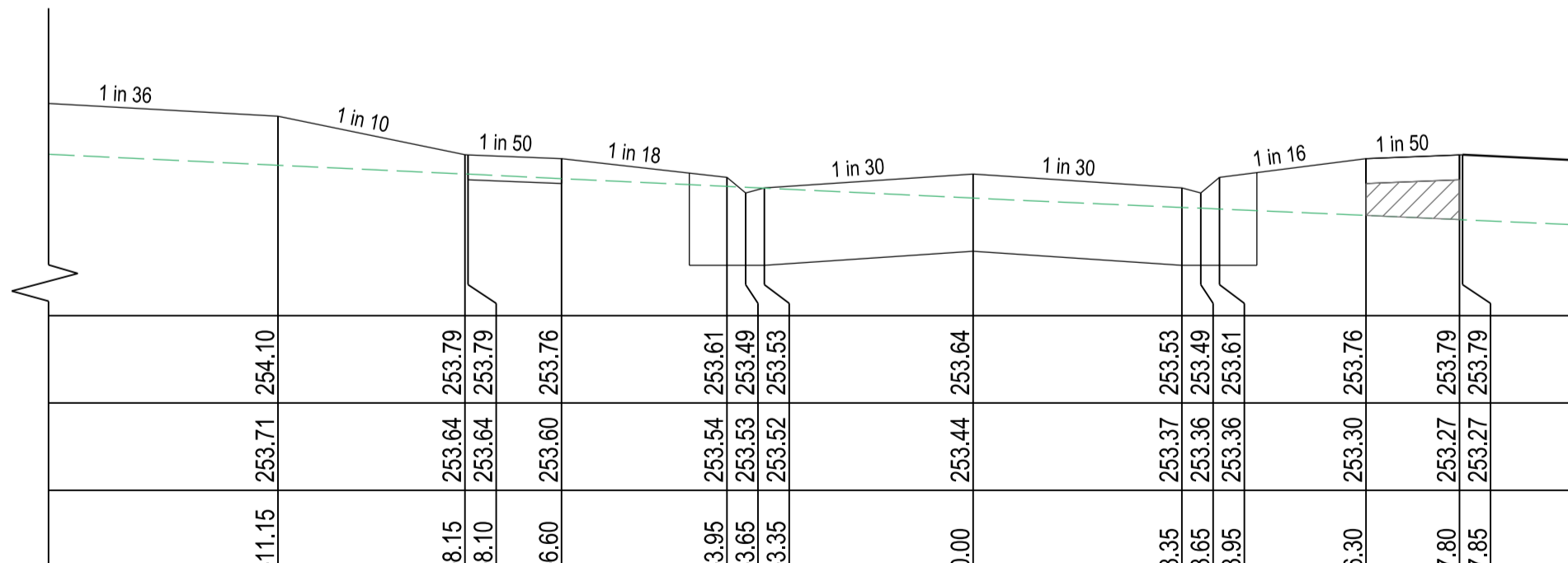

Ch 37.50

INDICATES CRUSHED ROCK BACKFILL

ALLOTMENT GRADE NOTE  
MINIMUM 1 IN 150 LOT GRADE INDICATED THUS:

ALLOTMENT BATTER NOTE  
IF NOT SHOWN FOR CLARITY ALL BATTERS WITHIN ALLOTMENTS TO BE GRADE 1 IN 5, UNLESS NOTED OTHERWISE

CROSS SECTIONS  
SCALE HORIZONTAL 1:100  
VERTICAL 1:50

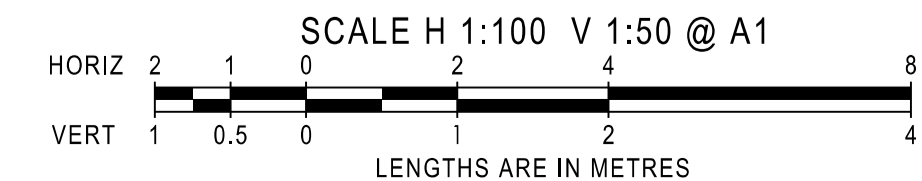

AMENDMENTS	VER	DATE	REMARKS	<p>breese pitt dixon pty. ltd. land surveyors civil engineers</p> <p>MELWAY REF. 386-F-3 SURVEY VERIS DESIGN R.W. DRAWN D.W. CHECKED A.K.</p>	<p>1/19 cato street hawthorn east, 3123 telephone 8823 2300 fax no. 8823 2310</p>	
	<p>CLOVERTON ESTATE STAGE 328 CROSS SECTIONS</p>					<p>MUNICIPALITY HUME</p>
	<p>SCALE AS SHOWN DATUM AHD DATE AUG '22</p>					<p>REFERENCE 8460 E/328</p>
	<p>SHEET 7 OF 16 P1</p>					<p>FILE NO: 14912623</p>



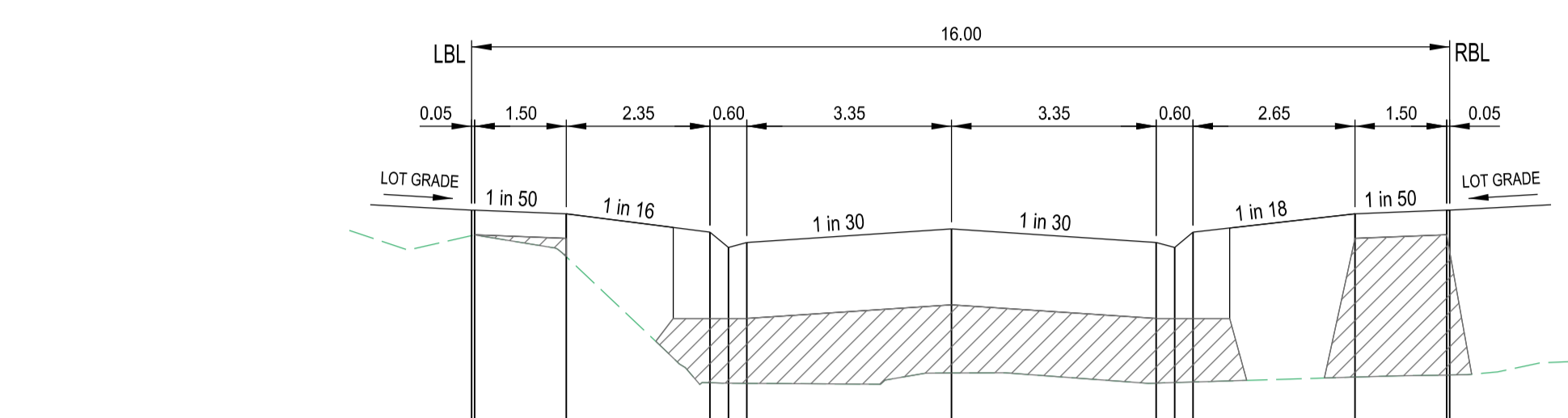

DATUM 248.50											
FINISHED SURFACE											
EXISTING SURFACE											
OFFSET											

MAGNESIUM ROAD Ch 128.20

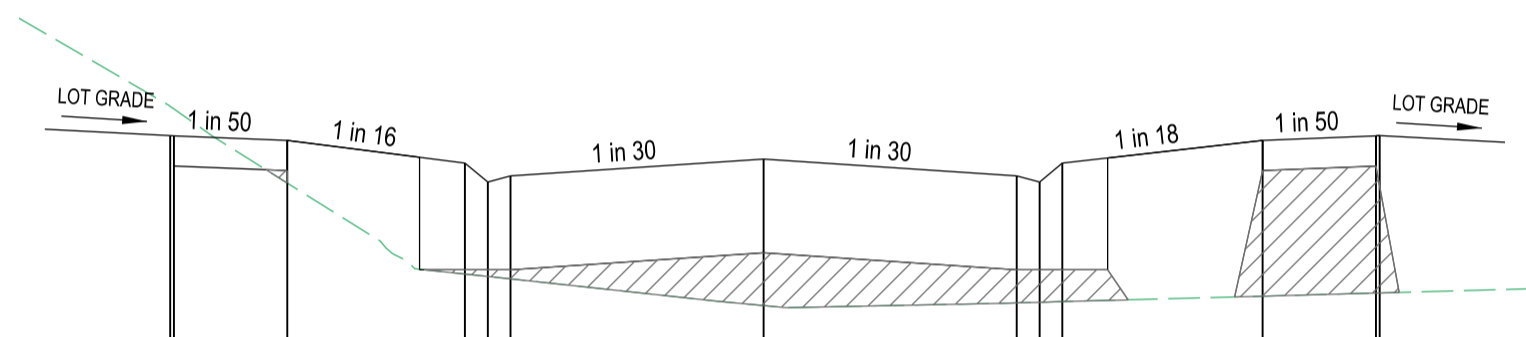

DATUM 248.50											
FINISHED SURFACE											
EXISTING SURFACE											
OFFSET											

MAGNESIUM ROAD Ch 101.70

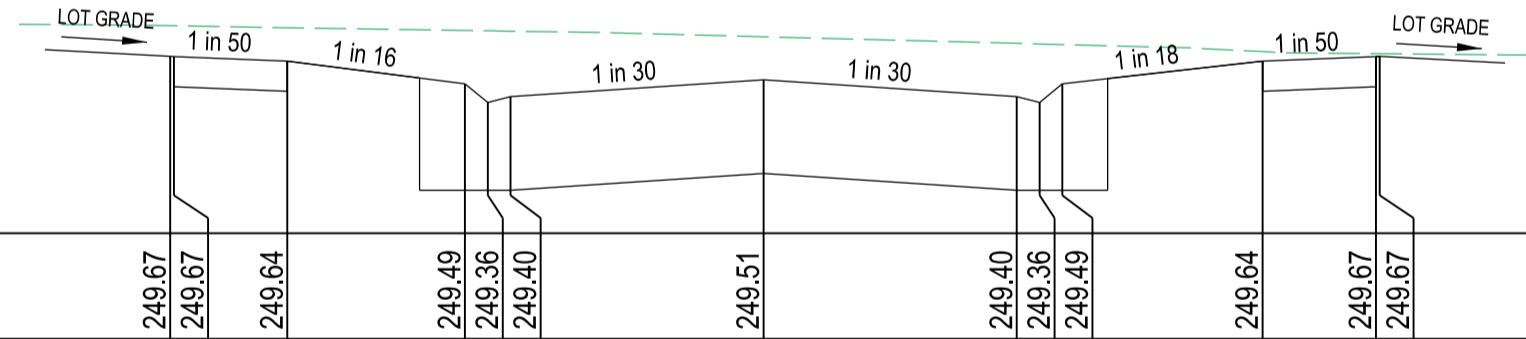

DATUM 248.50											
FINISHED SURFACE											
EXISTING SURFACE											
OFFSET											

MAGNESIUM ROAD Ch 75.20

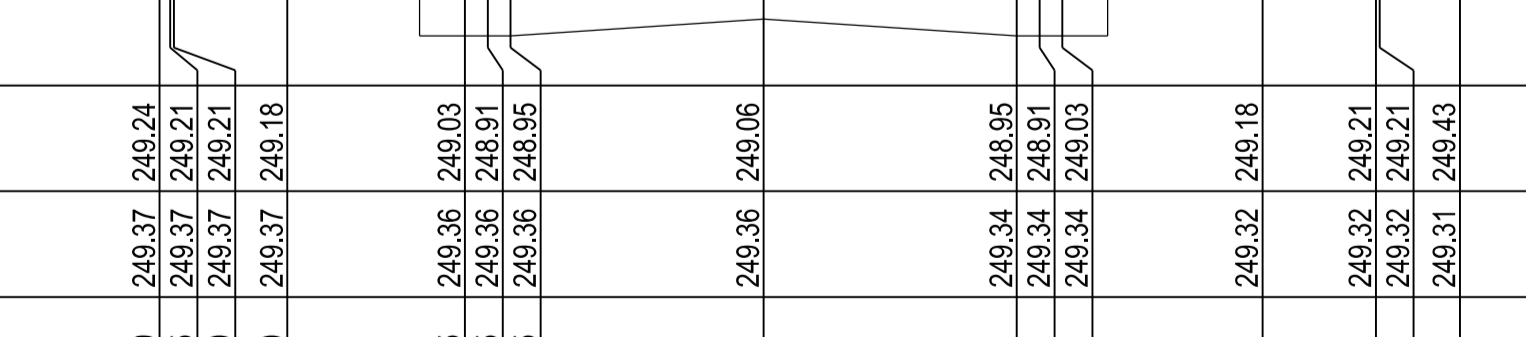

DATUM 248.00											
FINISHED SURFACE											
EXISTING SURFACE											
OFFSET											

MAGNESIUM ROAD Ch 50.20

**ALLOTMENT GRADE NOTE**  
 MINIMUM 1 IN 150 LOT GRADE  
 INDICATED THUS: LOT GRADE

**ALLOTMENT BATTER NOTE**  
 IF NOT SHOWN FOR CLARITY  
 ALL BATTERS WITHIN ALLOTMENTS  
 TO BE GRADE 1 IN 5.  
 UNLESS NOTED OTHERWISE

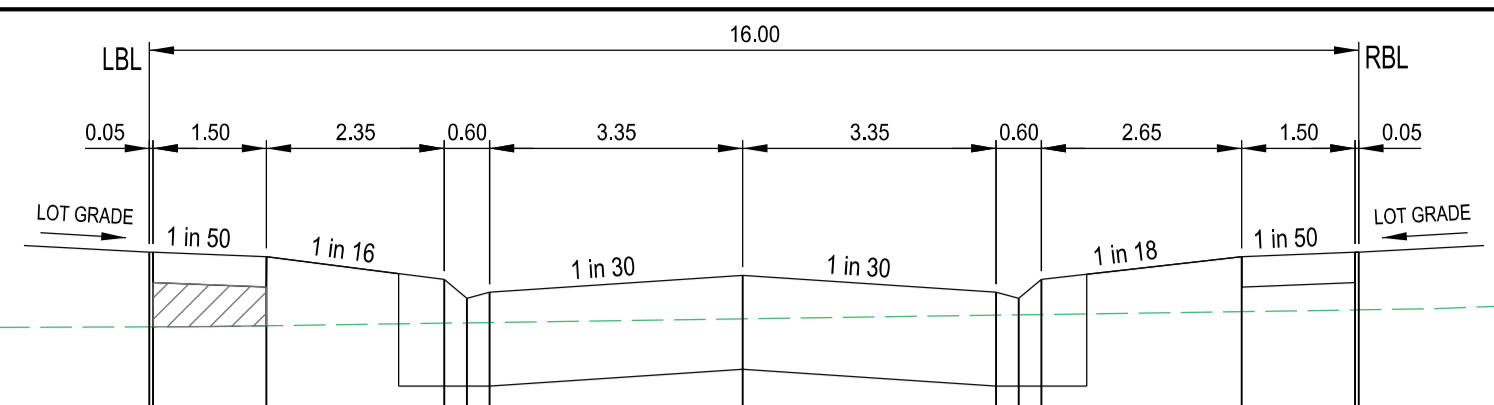
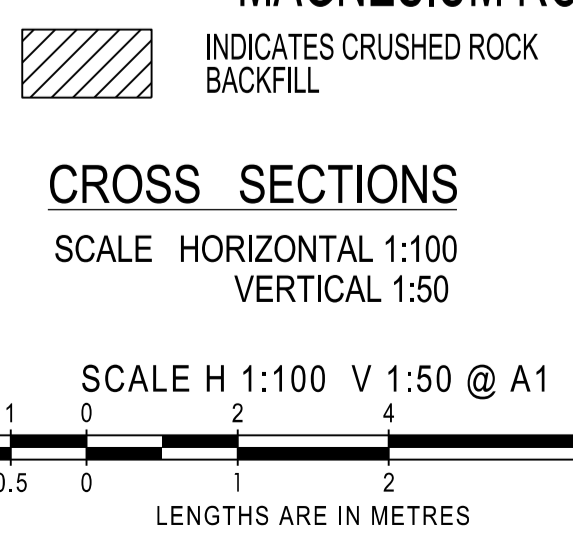

DATUM 253.00											
FINISHED SURFACE											
EXISTING SURFACE											
OFFSET											

MAGNESIUM ROAD Ch 259.20

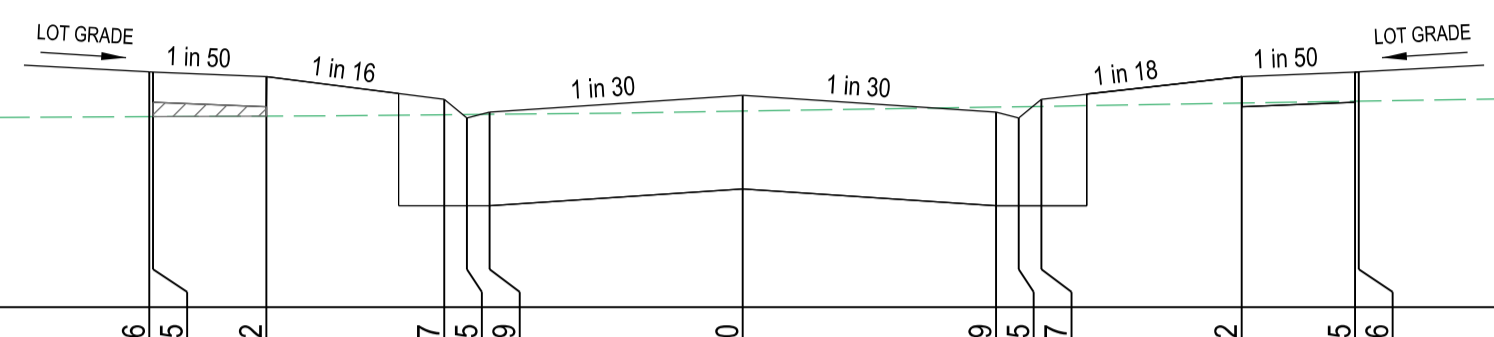

DATUM 252.00											
FINISHED SURFACE											
EXISTING SURFACE											
OFFSET											

MAGNESIUM ROAD Ch 240.00

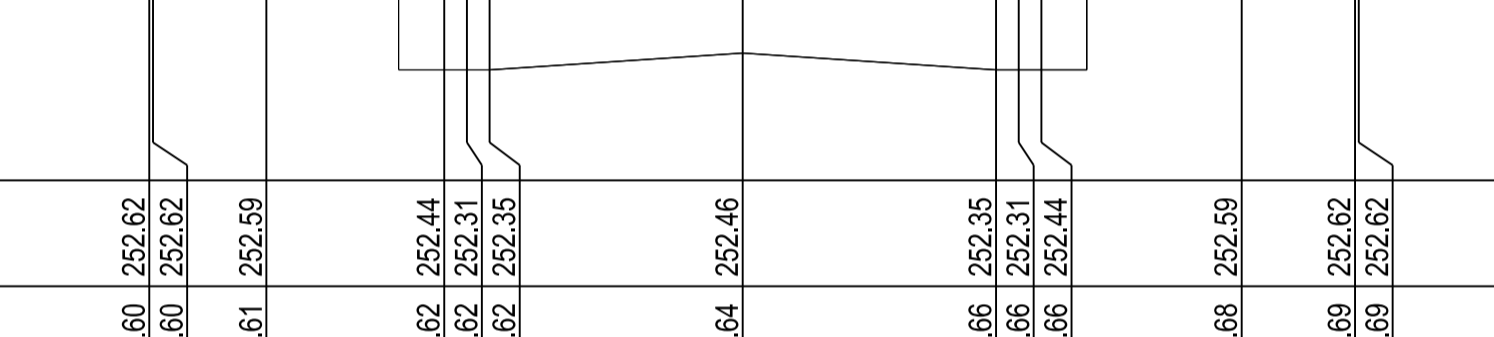

DATUM 251.00											
FINISHED SURFACE											
EXISTING SURFACE											
OFFSET											

MAGNESIUM ROAD Ch 216.10

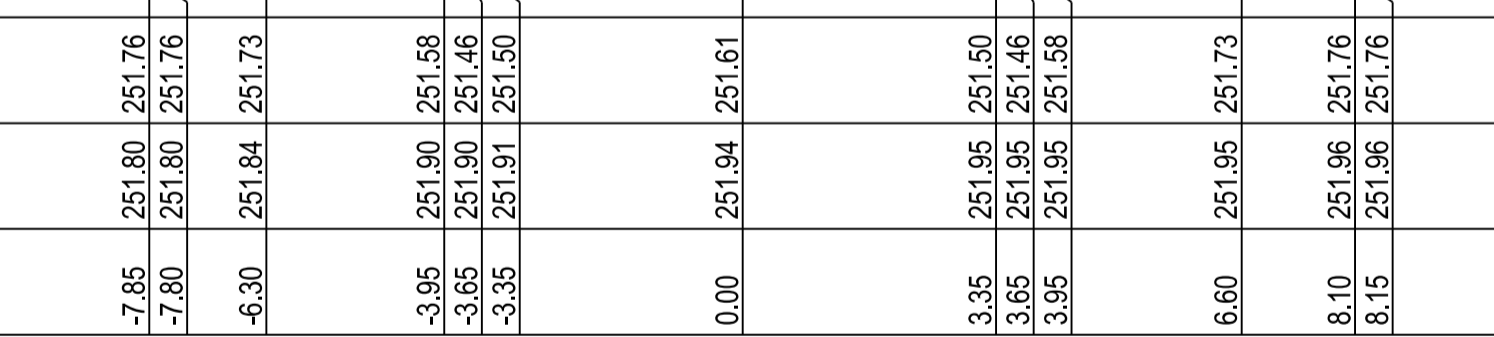

DATUM 250.50											
FINISHED SURFACE											
EXISTING SURFACE											
OFFSET											

MAGNESIUM ROAD Ch 188.70

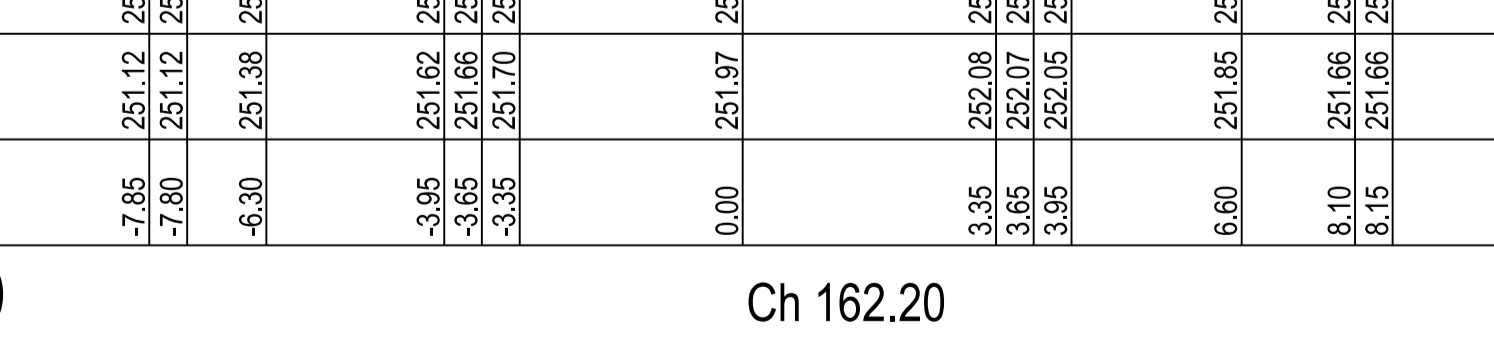

DATUM 250.00											
FINISHED SURFACE											
EXISTING SURFACE											
OFFSET											

MAGNESIUM ROAD Ch 162.20

AMENDMENTS VER DATE REMARKS				<b>breese pitt dixon pty. ltd.</b> land surveyors civil engineers		1/19 cato street hawthorn east, 3123 telephone 8823 2300 fax no. 8823 2310	
		MELWAY REF. 386-F-3		<b>CLOVERTON ESTATE</b> STAGE 328 CROSS SECTIONS		MUNICIPALITY <b>HUME</b>	
		SURVEY VERIS		DESIGN R.W.		REFERENCE 8460 E/328	
		DRAWN D.W.		CHECKED A.K.		SCALE AS SHOWN DATUM AHD DATE AUG'22 SHEET 8 OF 16 P1	

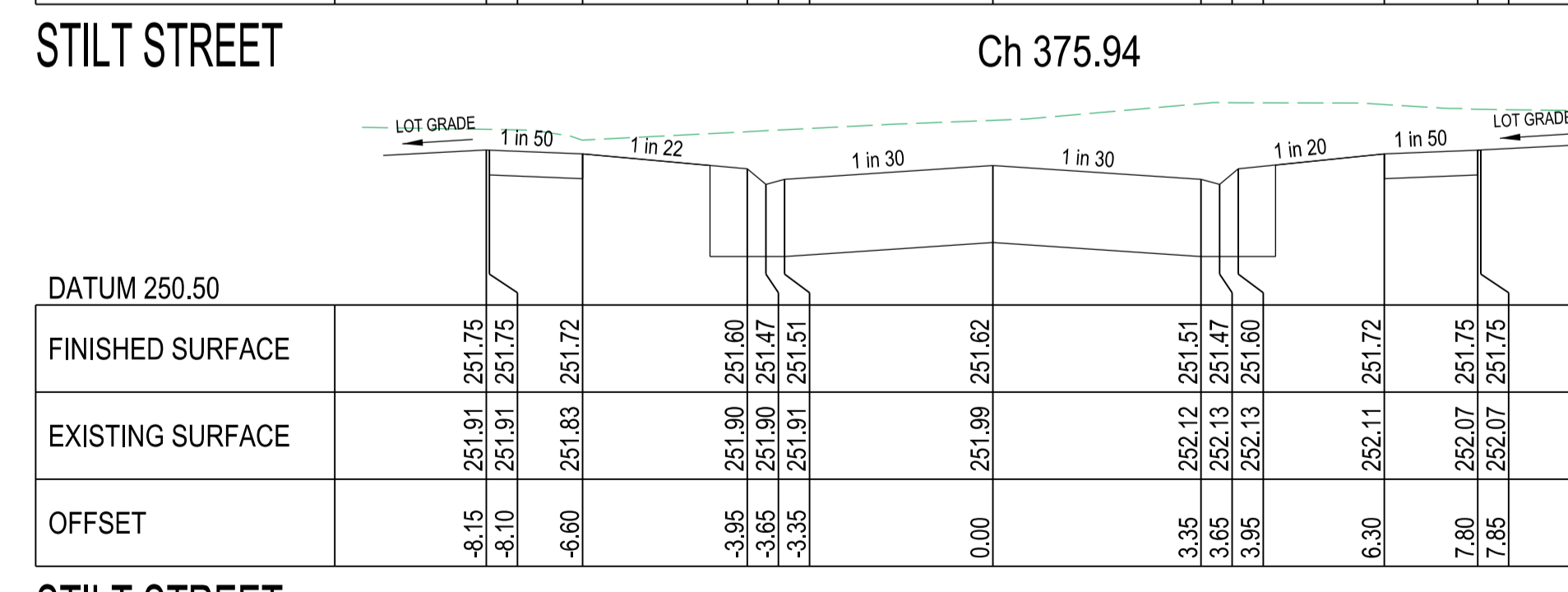
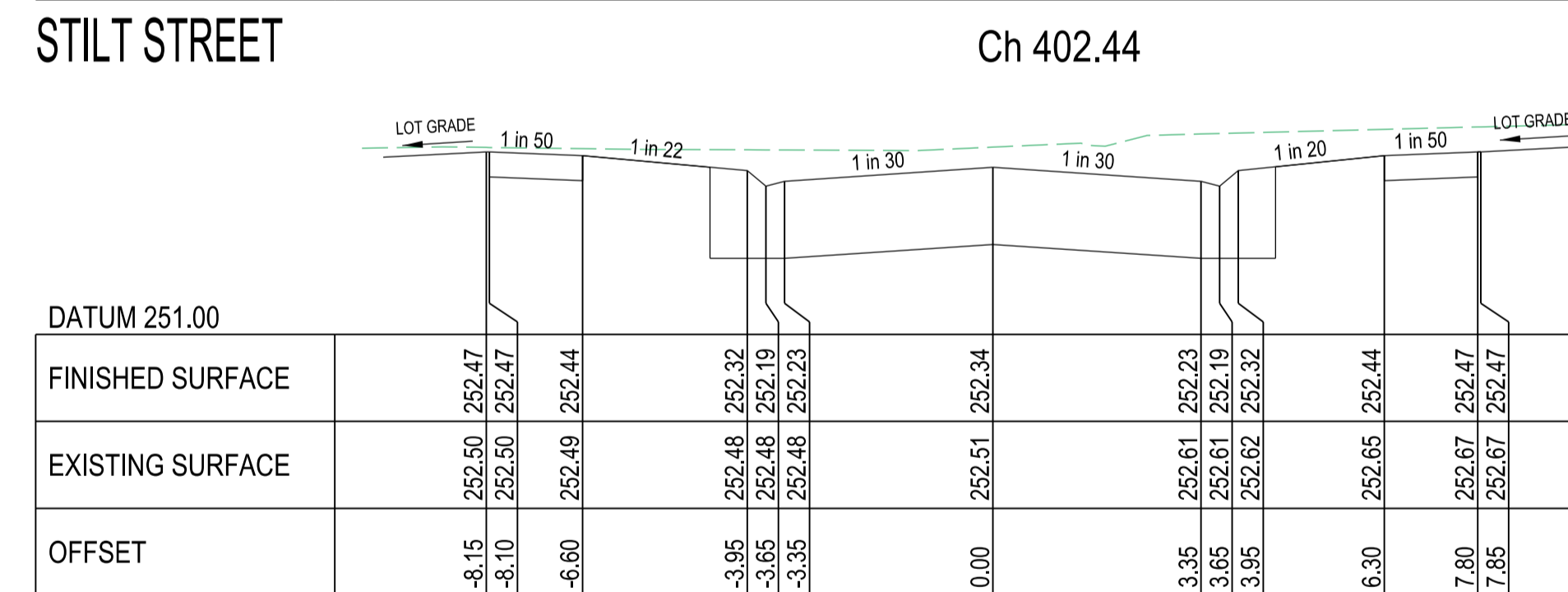
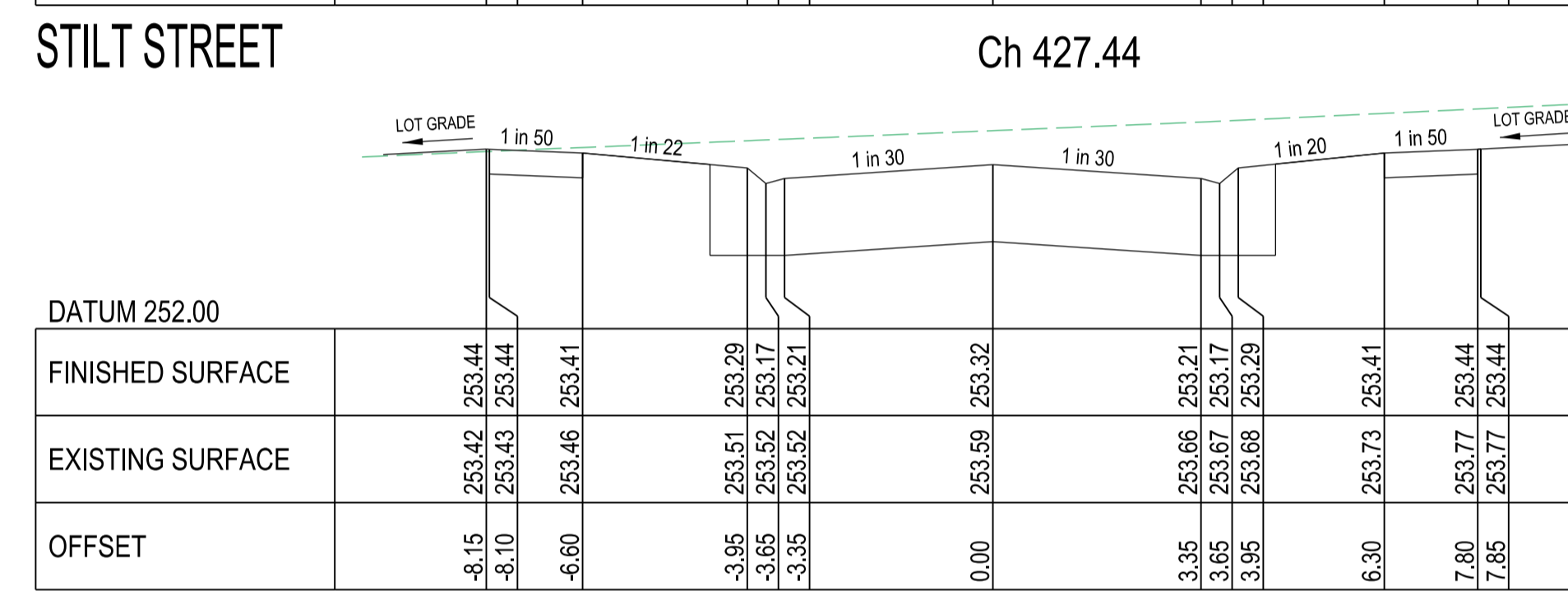
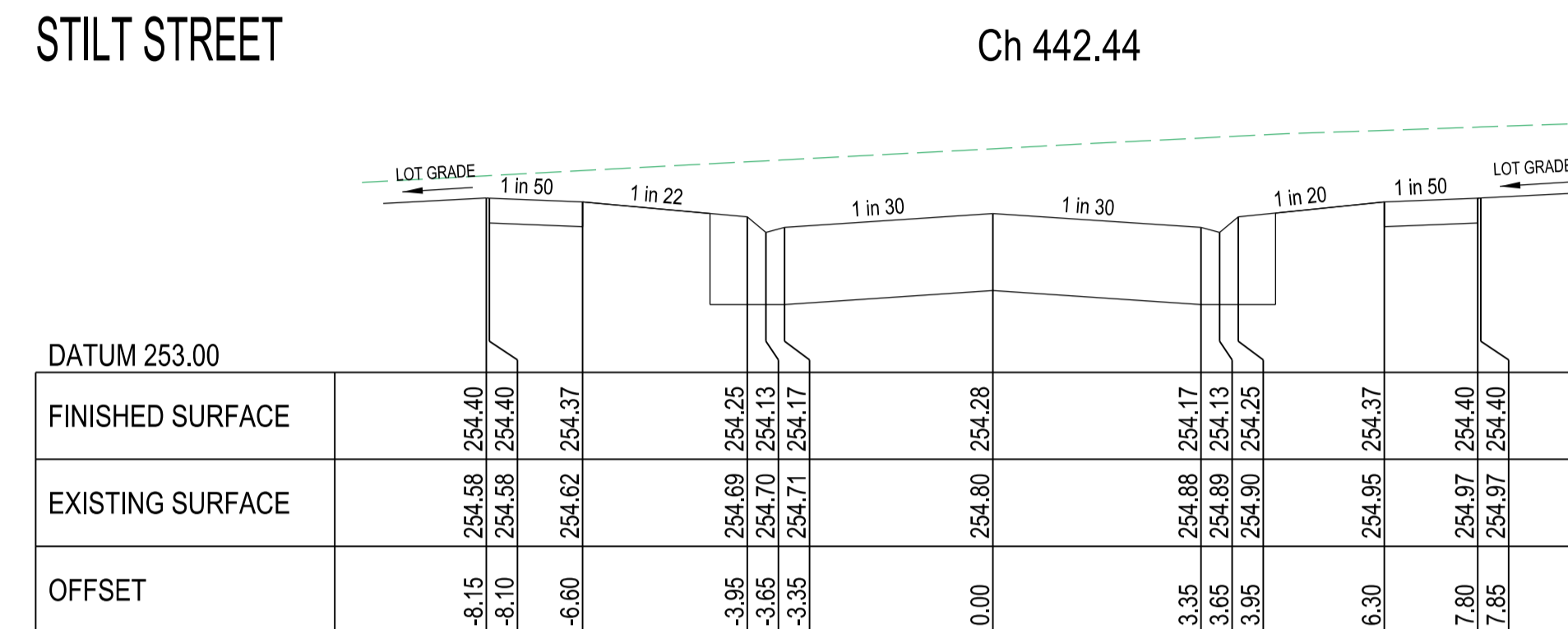
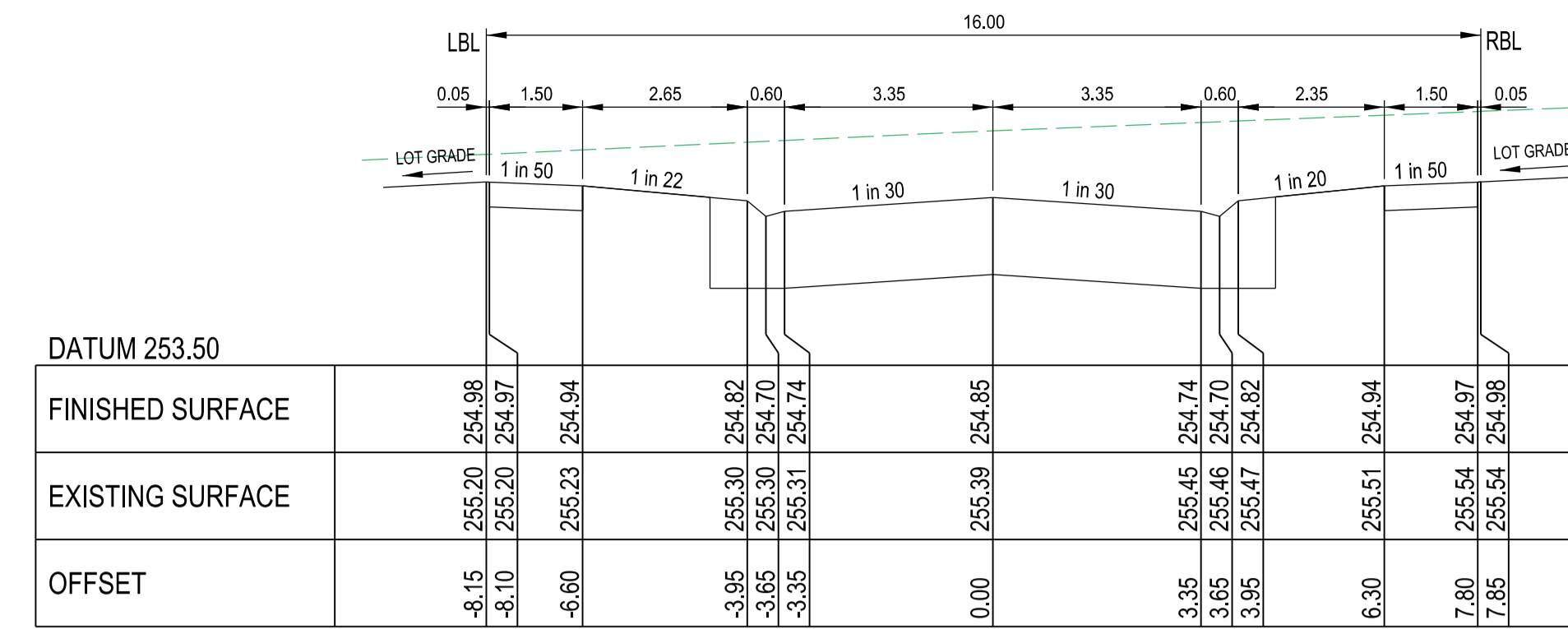
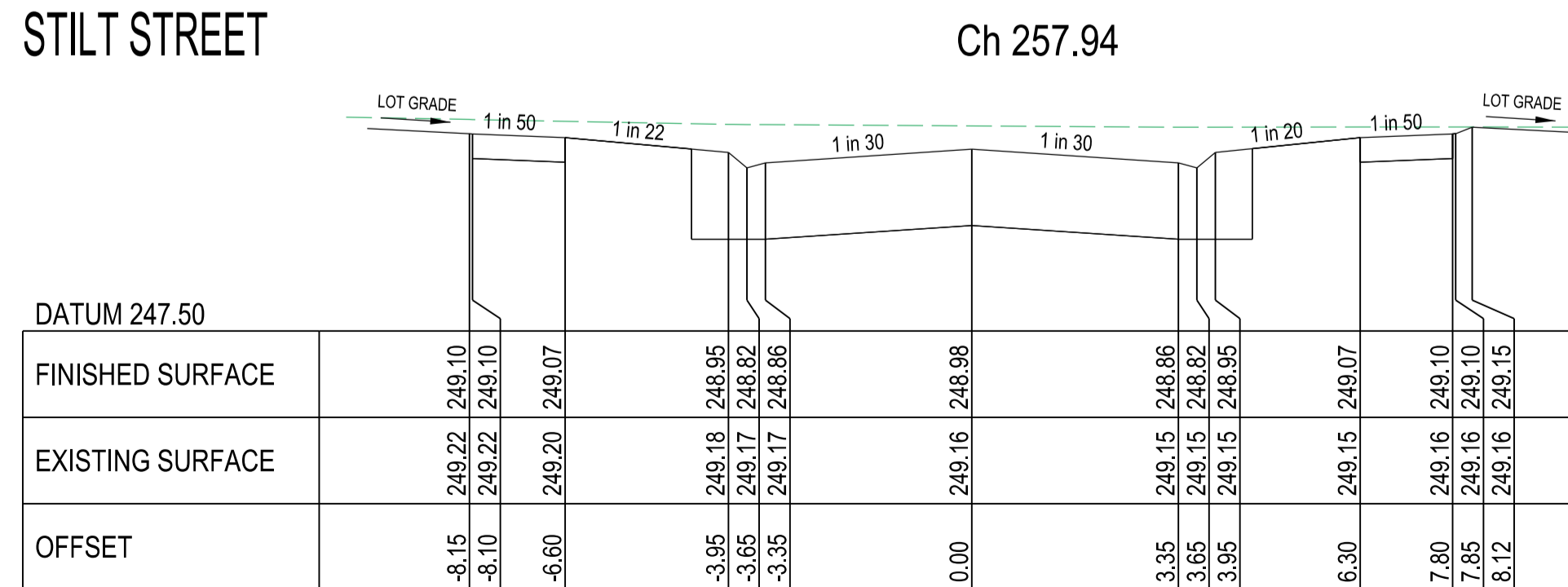
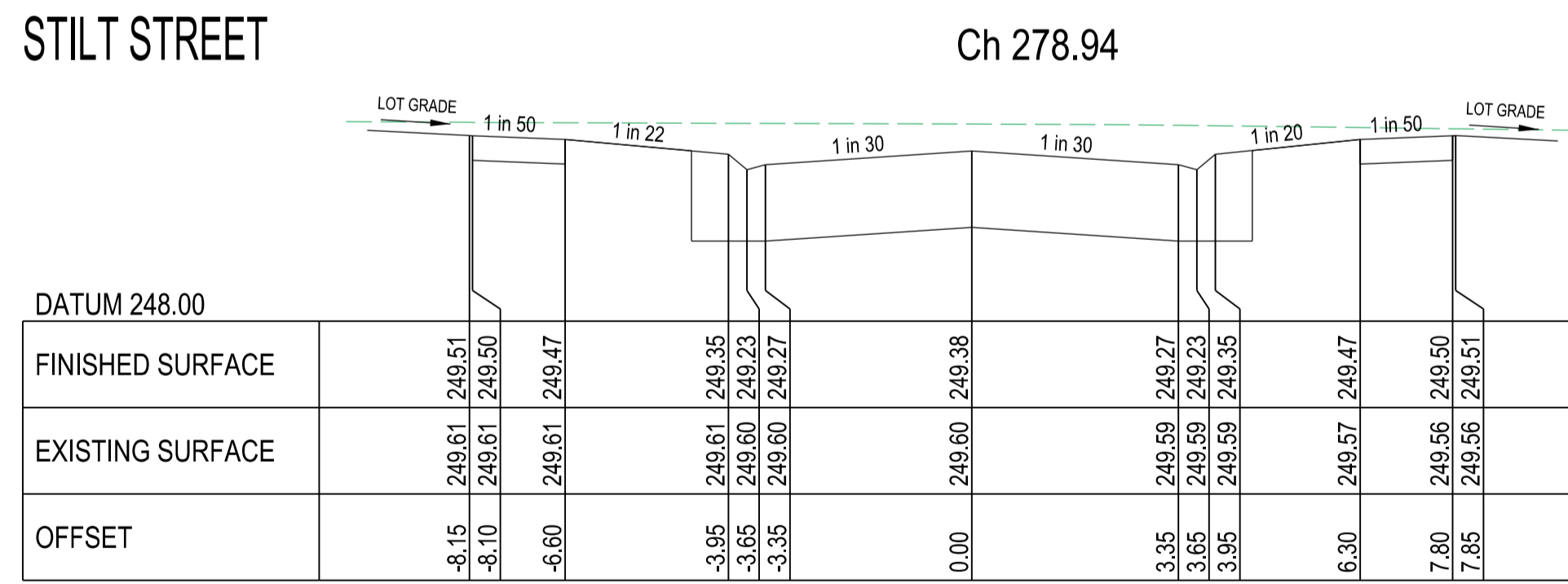
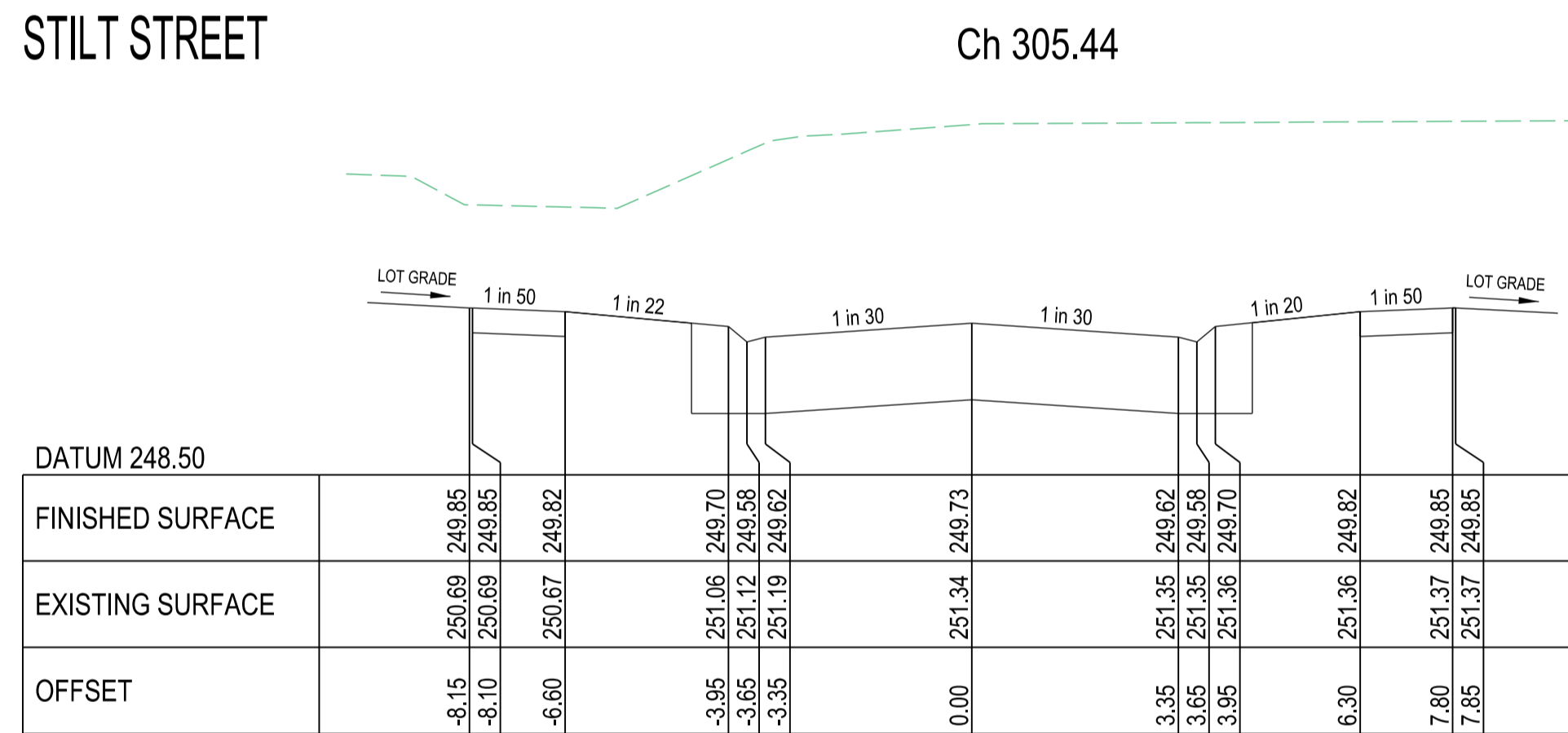
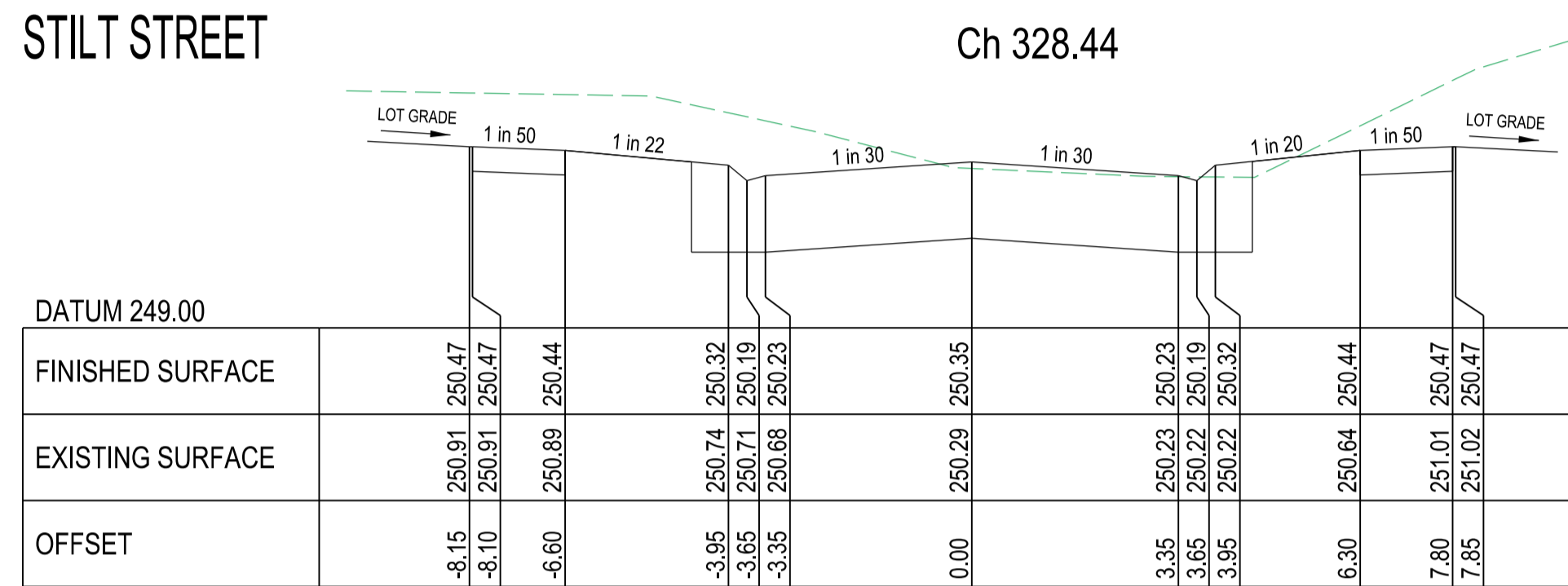
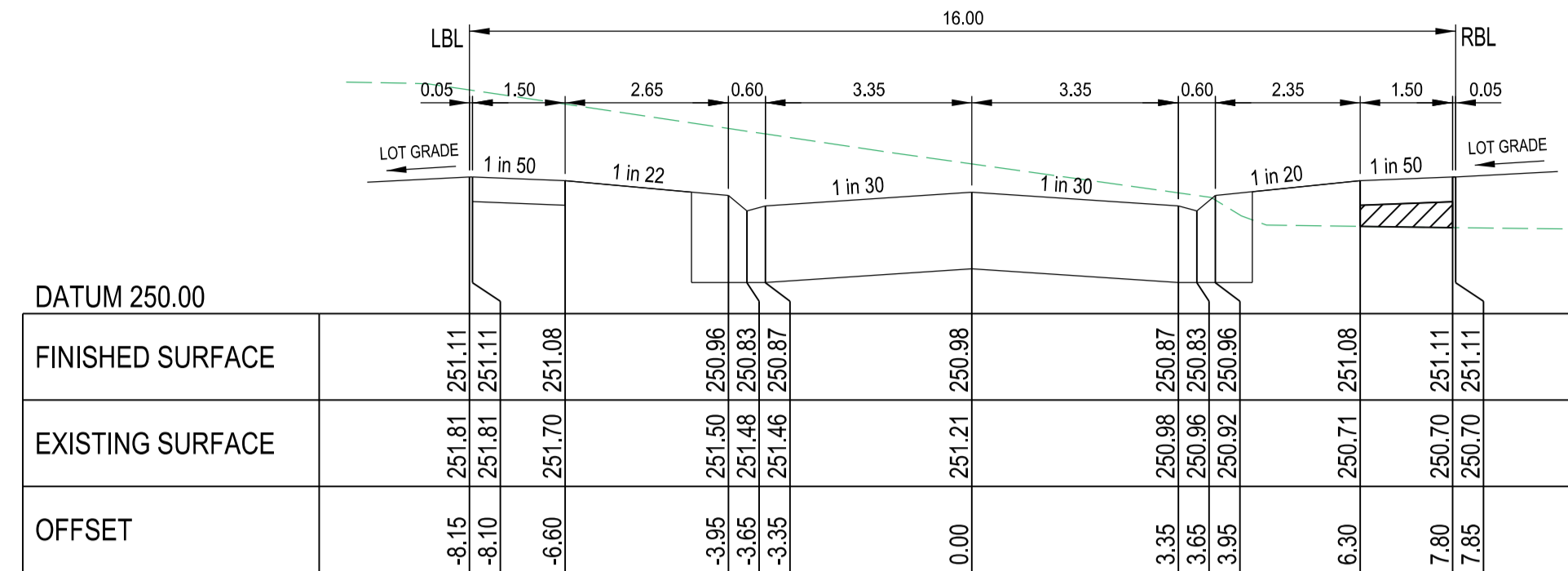

**ALLOTMENT GRADE NOTE**

MINIMUM 1 IN 150 LOT GRADE INDICATED THUS:

**ALLOTMENT BATTER NOTE**

IF NOT SHOWN FOR CLARITY ALL BATTERS WITHIN ALLOTMENTS TO BE GRADE 1 IN 5, UNLESS NOTED OTHERWISE

INDICATES CRUSHED ROCK BACKFILL

**CROSS SECTIONS**  
SCALE HORIZONTAL 1:100  
VERTICAL 1:50

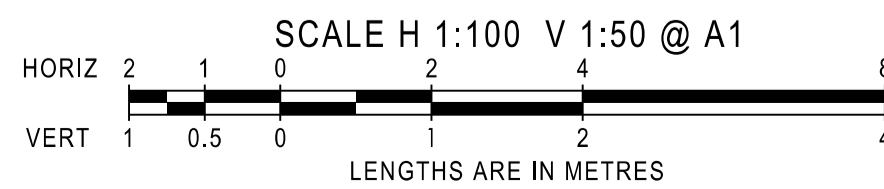

AMENDMENTS		<b>breese pitt dixon pty. ltd.</b> land surveyors civil engineers		1/19 cato street hawthorn east, 3123 telephone 8823 2300 fax no. 8823 2310	
		MELWAY REF.	386-F-3	MUNICIPALITY	
		SURVEY	VERIS	HUME	
		DESIGN	R.W.	REFERENCE	
		DRAWN	D.W.	8460 E/328	
		CHECKED	A.K.	SCALE	AS SHOWN
		DATE		DATUM	AHD
		REMARKS		DATE	AUG'22
				SHEET	9 OF 16
				P1	



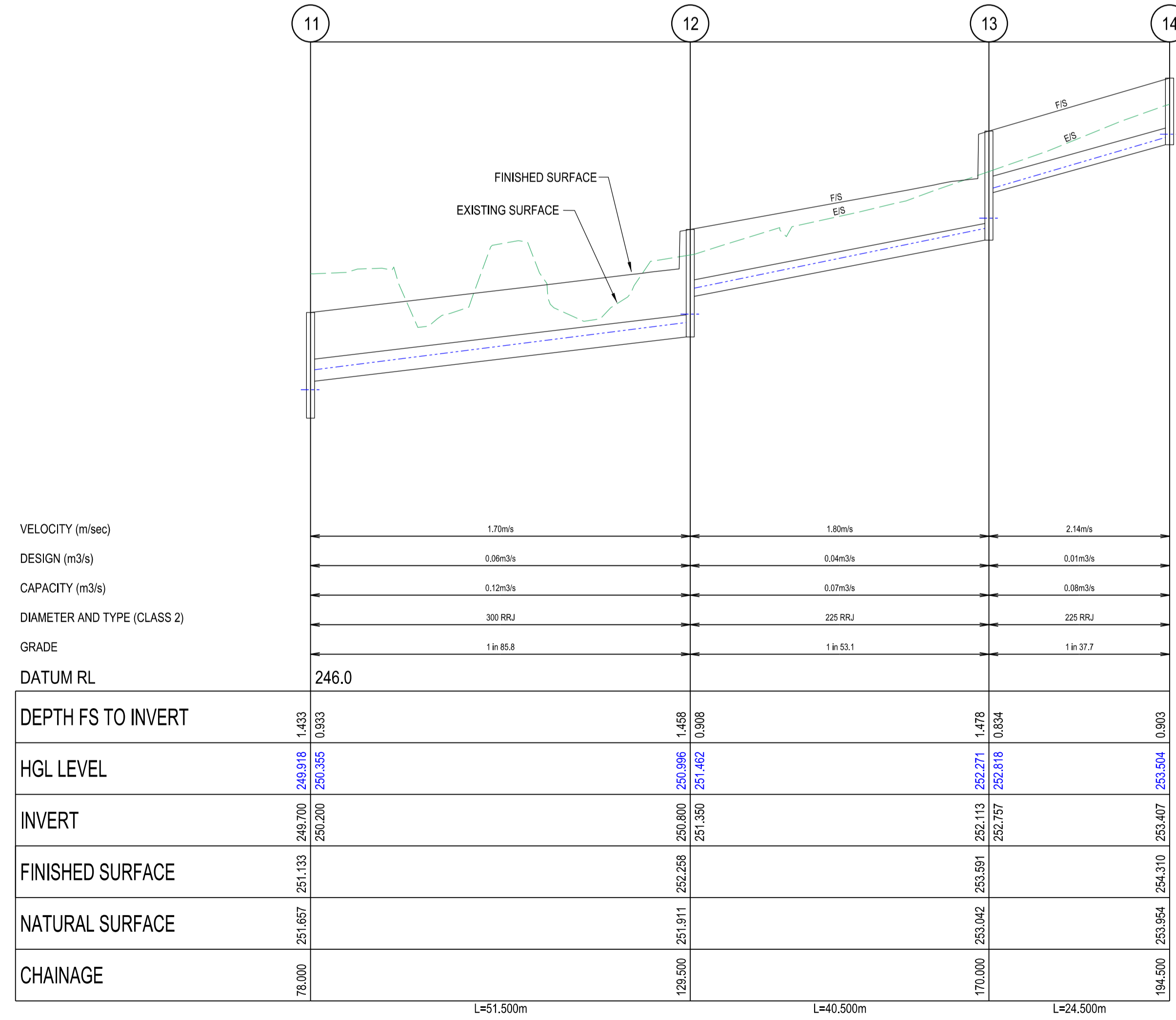
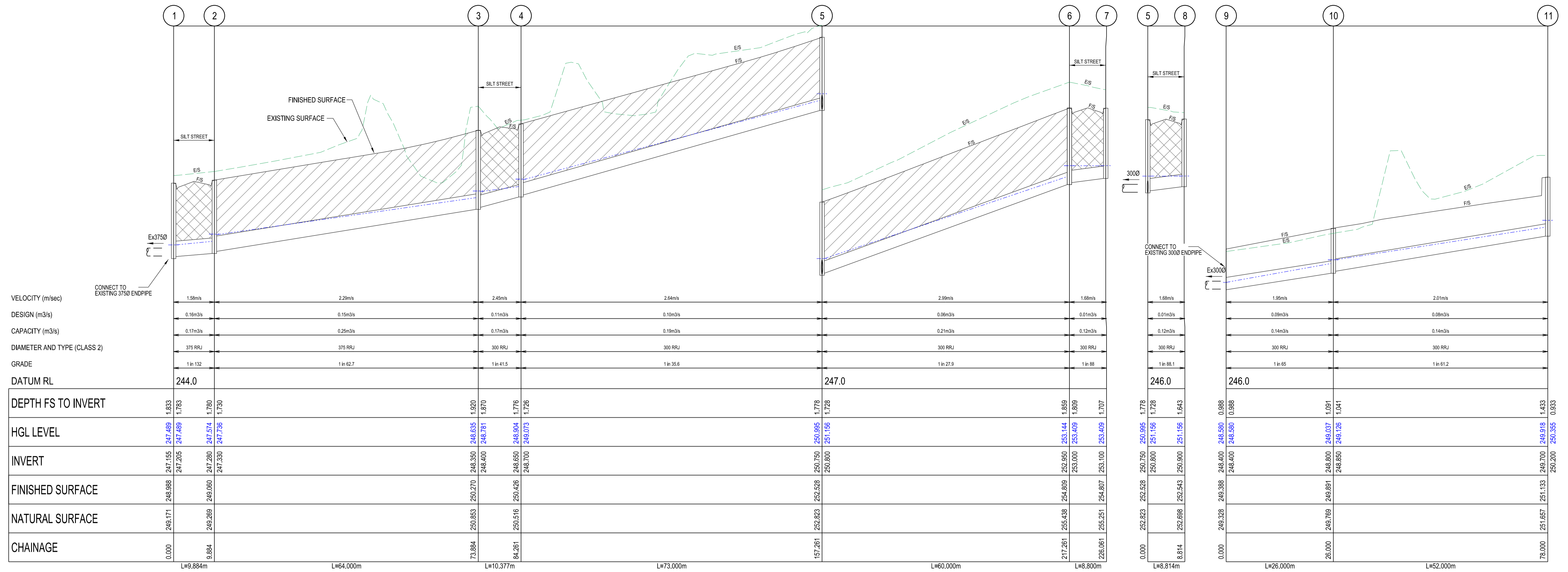

INDICATES CLASS 2 CRUSHED ROCK BACKFILL  
 INDICATES CLASS 3 CRUSHED ROCK BACKFILL  
 INDICATES 5YR HGL

**DRAINAGE LONGITUDINAL SECTIONS**  
 SCALE HORIZONTAL 1:500  
 VERTICAL 1:50  
 SCALE H 1:500 V 1:50 @ A1  
 HORIZ 10 5 0 10 20 40  
 VERT 1 0.5 0 2 4  
 LENGTHS ARE IN METRES

AMENDMENTS		<b>breese pitt dixon pty. ltd.</b> land surveyors civil engineers 1/19 cato street hawthorn east, 3123 telephone 8823 2300 fax no. 8823 2310	
	MELWAY REF. 367-F-3 SURVEY VERIS DESIGN R.W. DRAWN D.W.	<b>CLOVERTON ESTATE</b> <b>STAGE 328</b> <b>DRAINAGE LONG SECTIONS</b>	MUNICIPALITY <b>HUME</b> REFERENCE 8460 E/328
	CHECKED A.K. SCALE AS SHOWN DATUM AHD DATE AUG'22	SHEET 10 OF 16 P1	

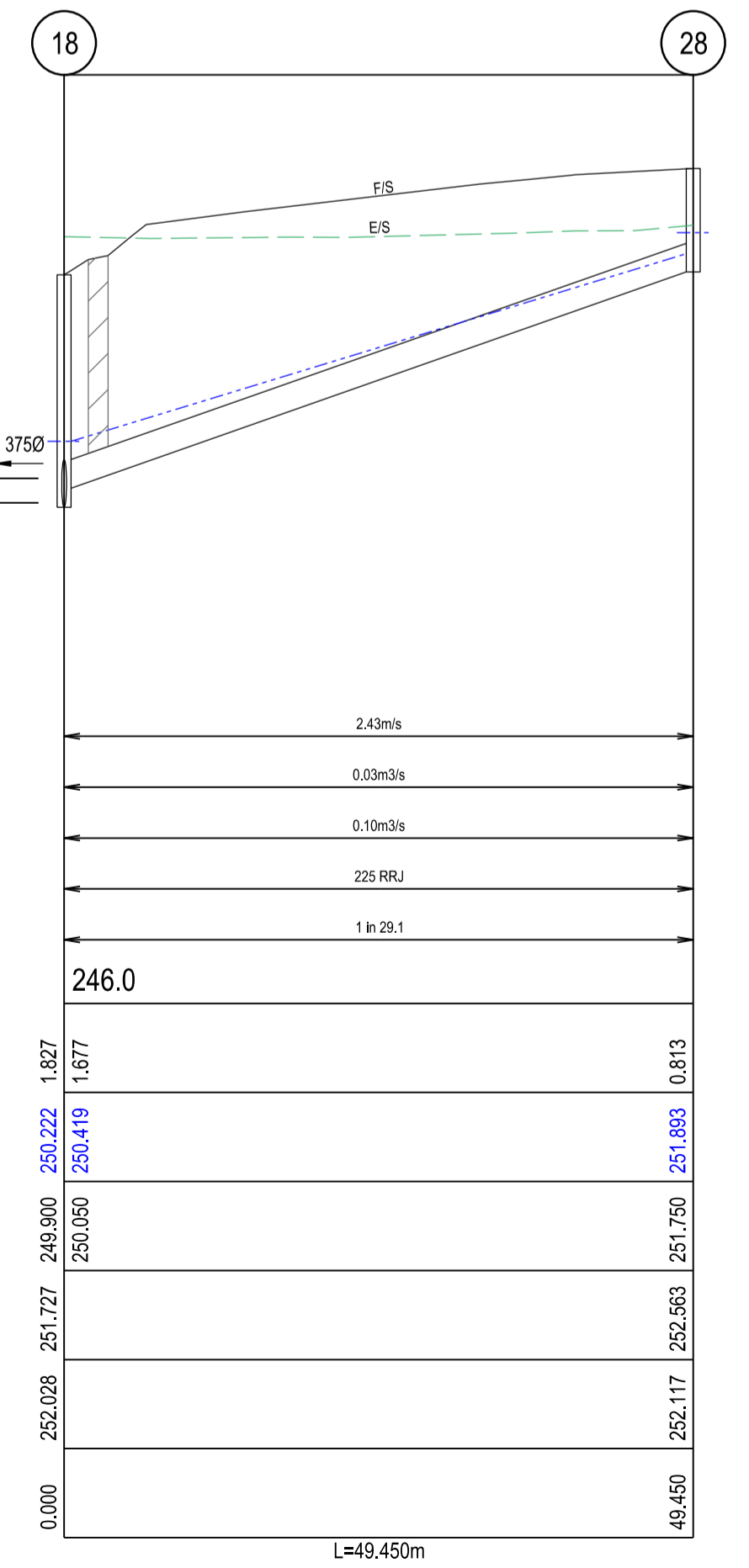
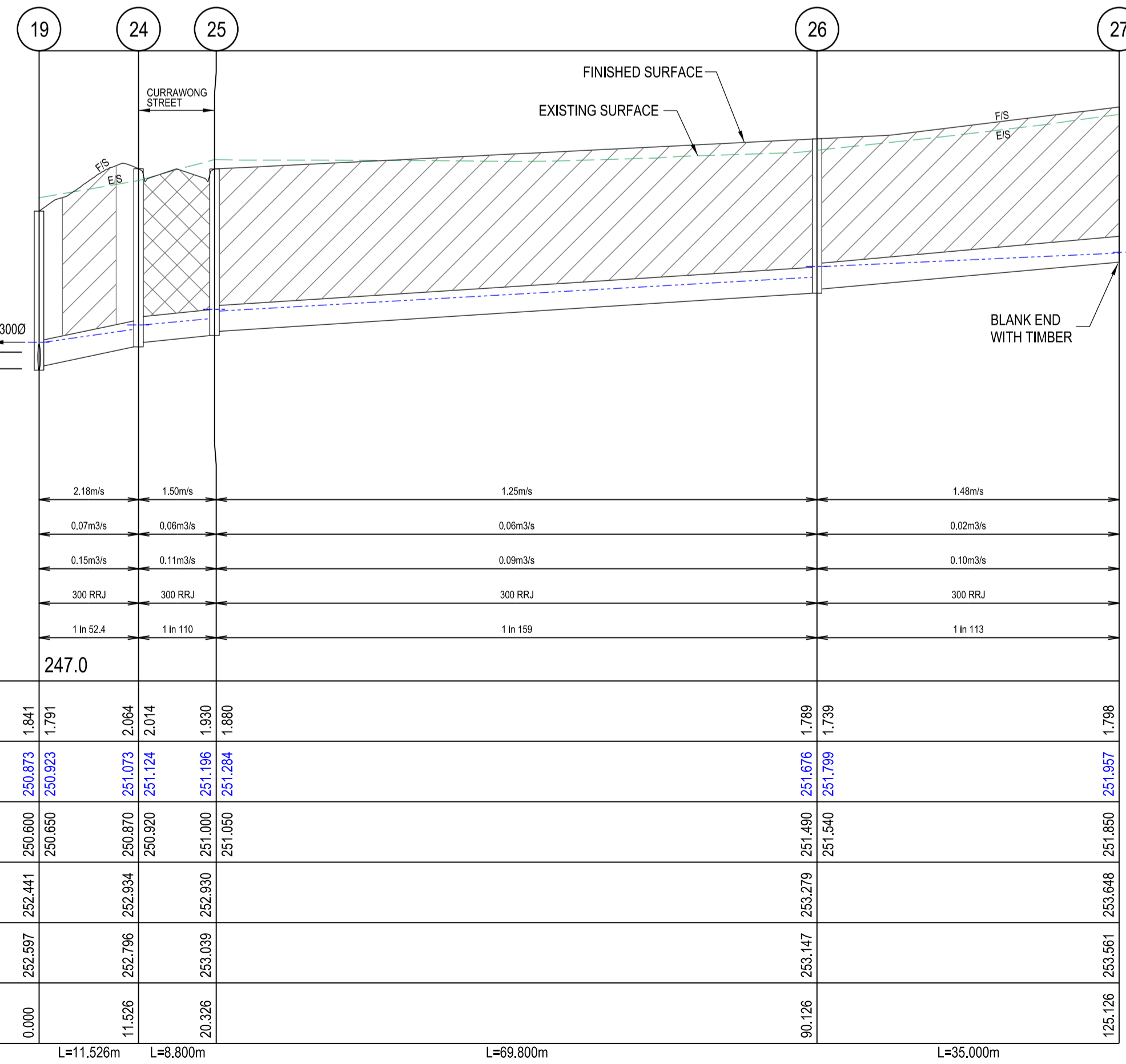
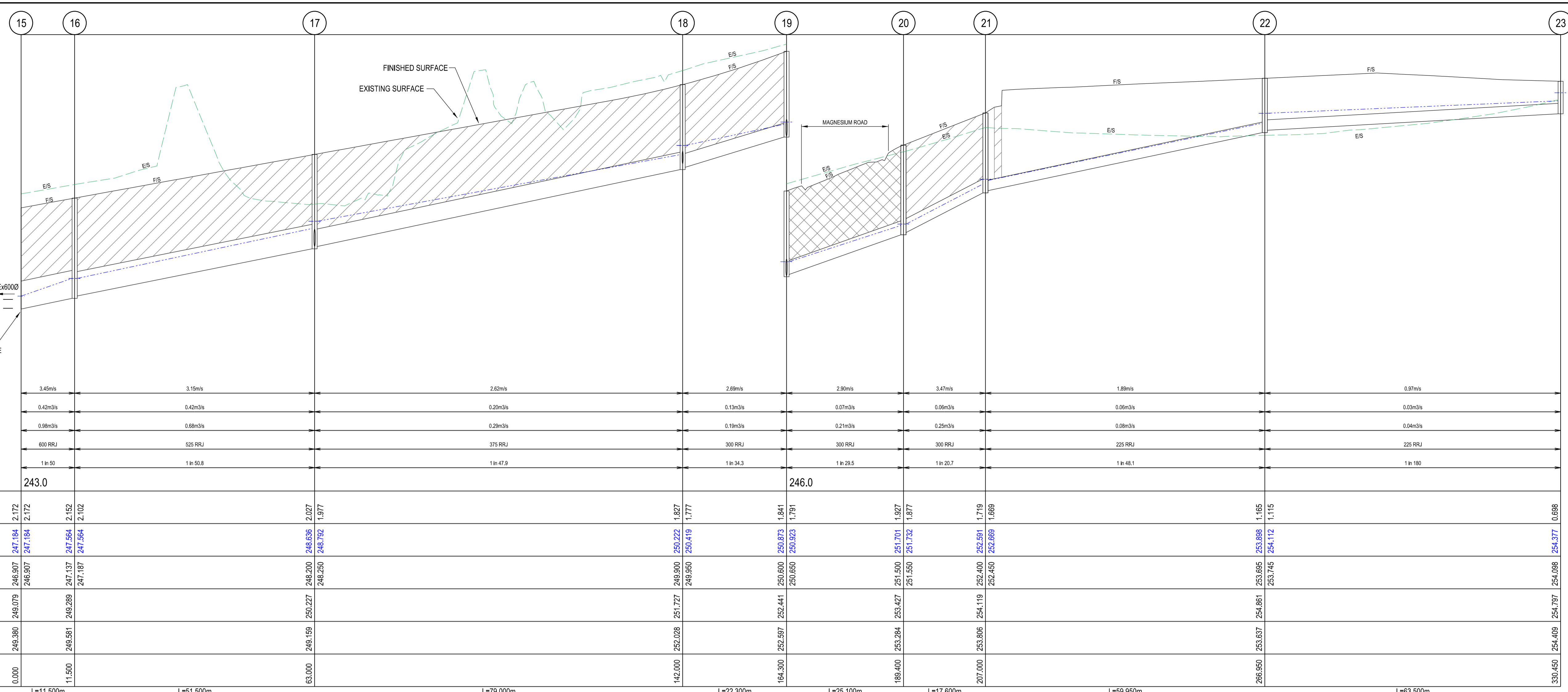

VELOCITY (m/sec)	3.45m/s	3.15m/s	2.62m/s	2.69m/s	2.80m/s	3.47m/s	1.89m/s	0.97m/s								
DESIGN (m <sup>3</sup> /s)	0.42m <sup>3</sup> /s	0.42m <sup>3</sup> /s	0.20m <sup>3</sup> /s	0.13m <sup>3</sup> /s	0.07m <sup>3</sup> /s	0.06m <sup>3</sup> /s	0.06m <sup>3</sup> /s	0.03m <sup>3</sup> /s								
CAPACITY (m <sup>3</sup> /s)	0.58m <sup>3</sup> /s	0.58m <sup>3</sup> /s	0.29m <sup>3</sup> /s	0.19m <sup>3</sup> /s	0.21m <sup>3</sup> /s	0.25m <sup>3</sup> /s	0.08m <sup>3</sup> /s	0.04m <sup>3</sup> /s								
DIAMETER AND TYPE (CLASS 2)	800 RRJ	525 RRJ	375 RRJ	300 RRJ	300 RRJ	300 RRJ	225 RRJ	225 RRJ								
GRADE	1 in 50	1 in 50.8	1 in 47.9	1 in 34.3	1 in 28.5	1 in 20.7	1 in 48.1	1 in 180								
DATUM RL	243.0			246.0												
DEPTH FS TO INVERT	2.172	2.172	2.027	1.877	1.841	1.791	1.689	0.688								
HGL LEVEL	247.184	247.184	246.636	250.222	250.419	251.701	251.732	254.377								
INVERT	245.007	245.007	244.200	249.900	250.600	251.500	252.400	253.088								
FINISHED SURFACE	249.079	249.079	250.227	251.727	252.441	253.427	254.119	254.797								
NATURAL SURFACE	249.380	249.581	249.159	252.028	252.597	253.284	253.806	254.409								
CHAINAGE	0.000	11.500	63.000	142.000	164.300	189.400	207.000	330.450								
	L=11,500m		L=51,500m		L=79,000m		L=22,300m		L=25,100m		L=17,600m		L=59,950m		L=63,500m	

VELOCITY (m/sec)	2.18m/s	1.50m/s	1.25m/s	1.48m/s				
DESIGN (m <sup>3</sup> /s)	0.07m <sup>3</sup> /s	0.06m <sup>3</sup> /s	0.06m <sup>3</sup> /s	0.02m <sup>3</sup> /s				
CAPACITY (m <sup>3</sup> /s)	0.15m <sup>3</sup> /s	0.11m <sup>3</sup> /s	0.09m <sup>3</sup> /s	0.10m <sup>3</sup> /s				
DIAMETER AND TYPE (CLASS 2)	300 RRJ	300 RRJ	300 RRJ	300 RRJ				
GRADE	1 in 52.4	1 in 110	1 in 159	1 in 113				
DATUM RL	247.0							
DEPTH FS TO INVERT	1.841	1.791	2.064	1.830				
HGL LEVEL	250.873	250.923	251.073	251.124				
INVERT	250.600	250.650	250.870	251.000				
FINISHED SURFACE	252.441	252.934	253.279	253.648				
NATURAL SURFACE	252.597	252.796	253.147	253.561				
CHAINAGE	0.000	11.526	20.326	125.126				
	L=11,526m		L=8,800m		L=69,800m		L=35,000m	

VELOCITY (m/sec)	2.43m/s
DESIGN (m <sup>3</sup> /s)	0.03m <sup>3</sup> /s
CAPACITY (m <sup>3</sup> /s)	0.10m <sup>3</sup> /s
DIAMETER AND TYPE (CLASS 2)	225 RRJ
GRADE	1 in 28.1
DATUM RL	246.0
DEPTH FS TO INVERT	1.827
HGL LEVEL	250.419
INVERT	250.050
FINISHED SURFACE	252.117
NATURAL SURFACE	252.593
CHAINAGE	49.450
	L=49,450m

INDICATES CLASS 2 CRUSHED ROCK BACKFILL  
 INDICATES CLASS 3 CRUSHED ROCK BACKFILL  
 INDICATES 5YR HGL

**DRAINAGE LONGITUDINAL SECTIONS**  
 SCALE HORIZONTAL 1:500  
 VERTICAL 1:50  
 SCALE H 1:500 V 1:50 @ A1  
 HORIZ 10 5 0 10 20 40  
 VERT 1 0.5 0 1 2 4  
 LENGTHS ARE IN METRES

 <b>breese pitt dixon pty. ltd.</b> land surveyors civil engineers		1/19 cato street hawthorn east, 3123 telephone 8823 2300 fax no. 8823 2310
MELWAY REF. 367-F-3 SURVEY VERIS DESIGN R.W. DRAWN D.W.		<b>CLOVERTON ESTATE          STAGE 328          DRAINAGE LONG SECTIONS</b>
AMENDMENTS VER DATE REMARKS		MUNICIPALITY <b>HUME</b> REFERENCE 8460 E/328
CHECKED	A.K.	SCALE AS SHOWN DATUM AHD DATE AUG'22 SHEET 11 OF 16 P1



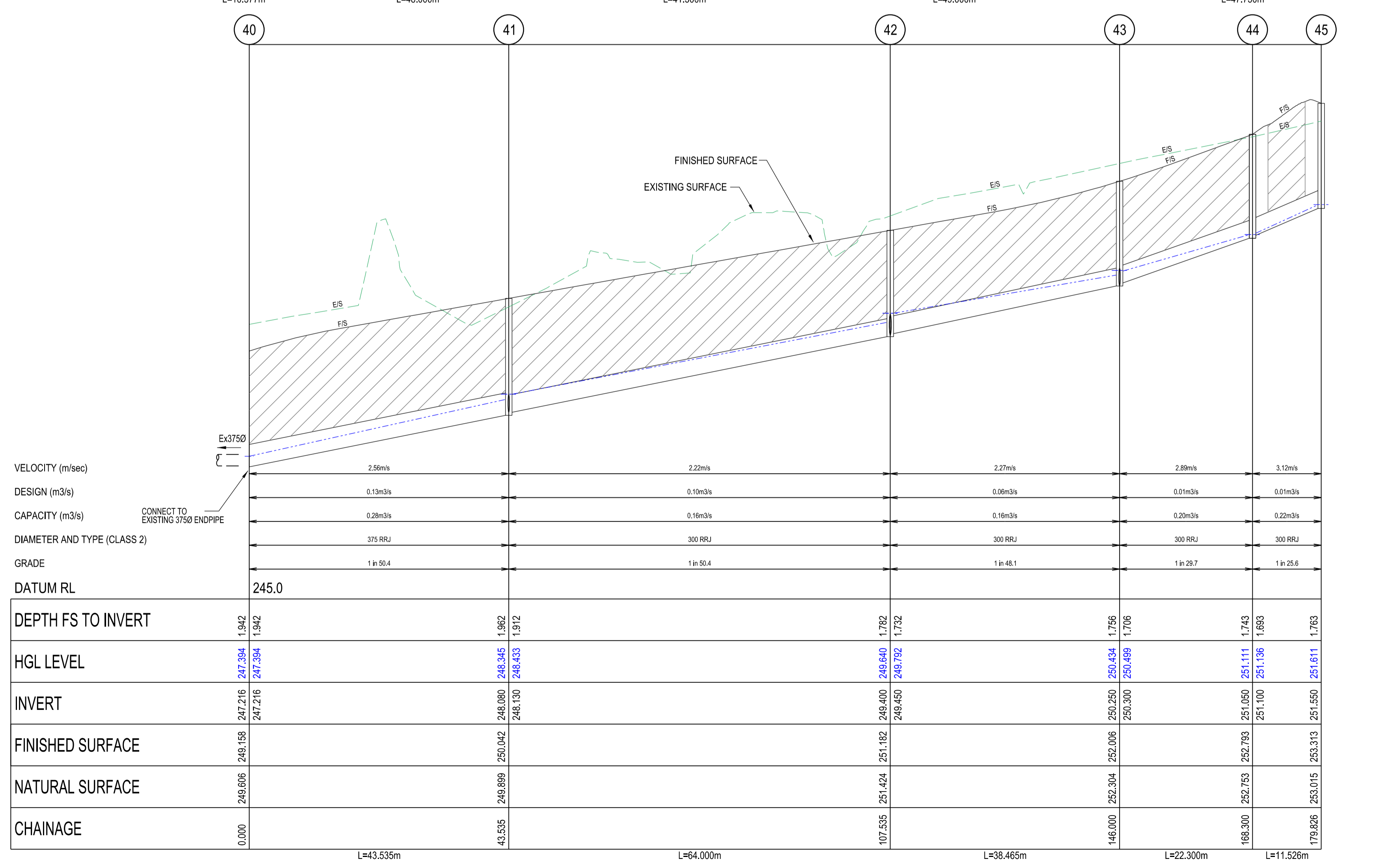
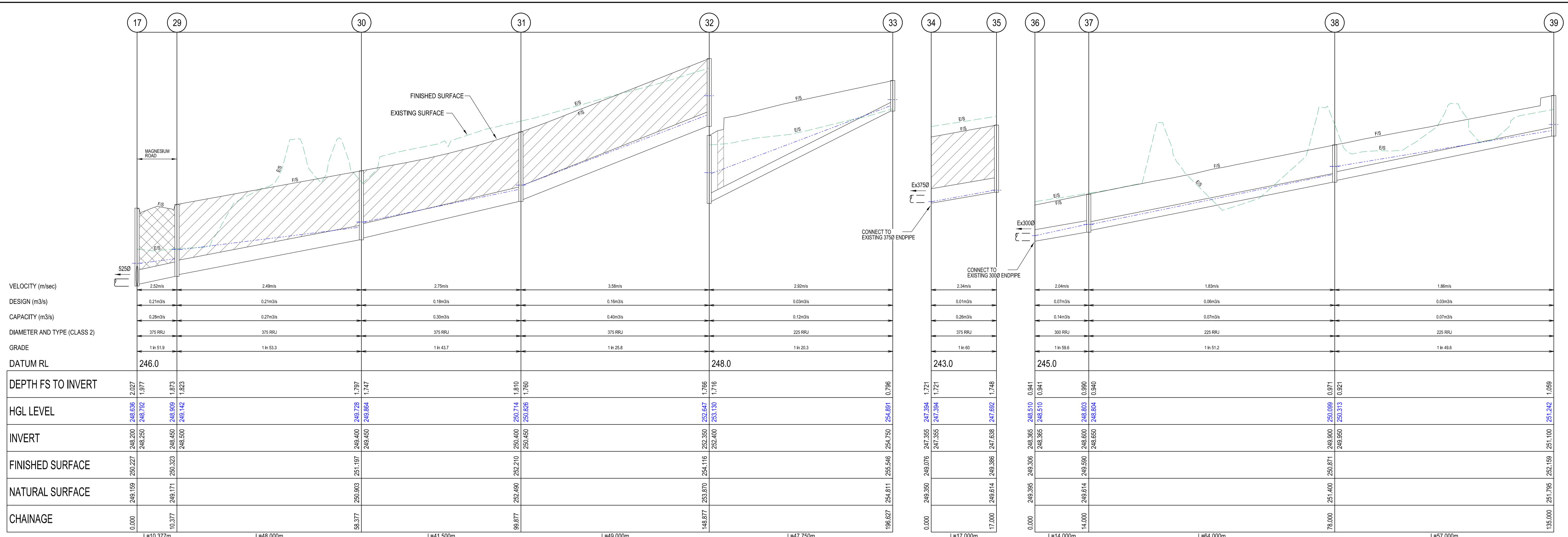

VELOCITY (m/sec)	2.52m/s	2.48m/s	2.75m/s	3.58m/s	2.92m/s	2.34m/s	2.04m/s	1.83m/s	1.88m/s
DESIGN (m3/s)	0.21m3/s	0.21m3/s	0.18m3/s	0.18m3/s	0.03m3/s	0.01m3/s	0.07m3/s	0.06m3/s	0.03m3/s
CAPACITY (m3/s)	0.28m3/s	0.27m3/s	0.30m3/s	0.40m3/s	0.12m3/s	0.26m3/s	0.14m3/s	0.07m3/s	0.07m3/s
DIAMETER AND TYPE (CLASS 2)	375 RRJ	375 RRJ	375 RRJ	375 RRJ	225 RRJ	375 RRJ	300 RRJ	225 RRJ	225 RRJ
GRADE	1 in 51.9	1 in 53.3	1 in 43.7	1 in 25.8	1 in 20.3	1 in 60	1 in 59.6	1 in 51.2	1 in 49.6
DATUM RL	246.0				248.0	243.0	245.0		
DEPTH FS TO INVERT	2.027	1.977				1.721	0.941	0.871	1.059
HGL LEVEL	248.636	248.152	248.909	248.142	248.823	247.394	248.510	250.069	251.242
INVERT	248.200	248.250	248.450	248.500	249.400	249.450	249.400	249.900	249.950
FINISHED SURFACE	250.227	249.323	251.197	252.210	254.116	252.350	252.400	252.647	253.130
NATURAL SURFACE	249.159	249.171	249.171	249.450	253.870	253.870	249.614	249.614	249.614
CHAINAGE	0.000	10.377	58.377	99.877	148.877	196.627	213.627	227.627	284.627

VELOCITY (m/sec)	2.56m/s	2.22m/s	2.27m/s	2.89m/s	3.12m/s
DESIGN (m3/s)	0.13m3/s	0.10m3/s	0.06m3/s	0.01m3/s	0.01m3/s
CAPACITY (m3/s)	0.28m3/s	0.18m3/s	0.16m3/s	0.20m3/s	0.22m3/s
DIAMETER AND TYPE (CLASS 2)	375 RRJ	300 RRJ	300 RRJ	300 RRJ	300 RRJ
GRADE	1 in 50.4	1 in 50.4	1 in 48.1	1 in 29.7	1 in 25.6
DATUM RL	245.0				
DEPTH FS TO INVERT	1.942	1.942	1.762	1.756	1.743
HGL LEVEL	247.394	248.345	248.792	250.434	251.111
INVERT	247.216	248.080	248.130	250.250	251.100
FINISHED SURFACE	249.158	250.042	251.162	252.006	252.793
NATURAL SURFACE	249.606	249.606	251.424	252.304	252.793
CHAINAGE	0.000	43.535	107.535	146.000	168.300

INDICATES CLASS 2 CRUSHED ROCK BACKFILL  
 INDICATES CLASS 3 CRUSHED ROCK BACKFILL  
 INDICATES 5YR HGL

**DRAINAGE LONGITUDINAL SECTIONS**  
 SCALE HORIZONTAL 1:500  
 VERTICAL 1:50  
 SCALE H 1:500 V 1:50 @ A1  
 HORIZ 10 5 0 10 20 40  
 VERT 1 0.5 0 1 2 4  
 LENGTHS ARE IN METRES

AMENDMENTS		<b>breese pitt dixon pty. ltd.</b> land surveyors civil engineers	1/19 cato street hawthorn east, 3123 telephone 8823 2300 fax no. 8823 2310	
			MELWAY REF. 367-F-3	MUNICIPALITY HUME
			SURVEY VERIS	REFERENCE 8460 <sup>E</sup> /328
			DESIGN R.W.	
		DRAWN D.W.		
		CHECKED A.K.	SCALE AS SHOWN DATUM AHD DATE AUG'22 SHEET 12 OF 16 P1	



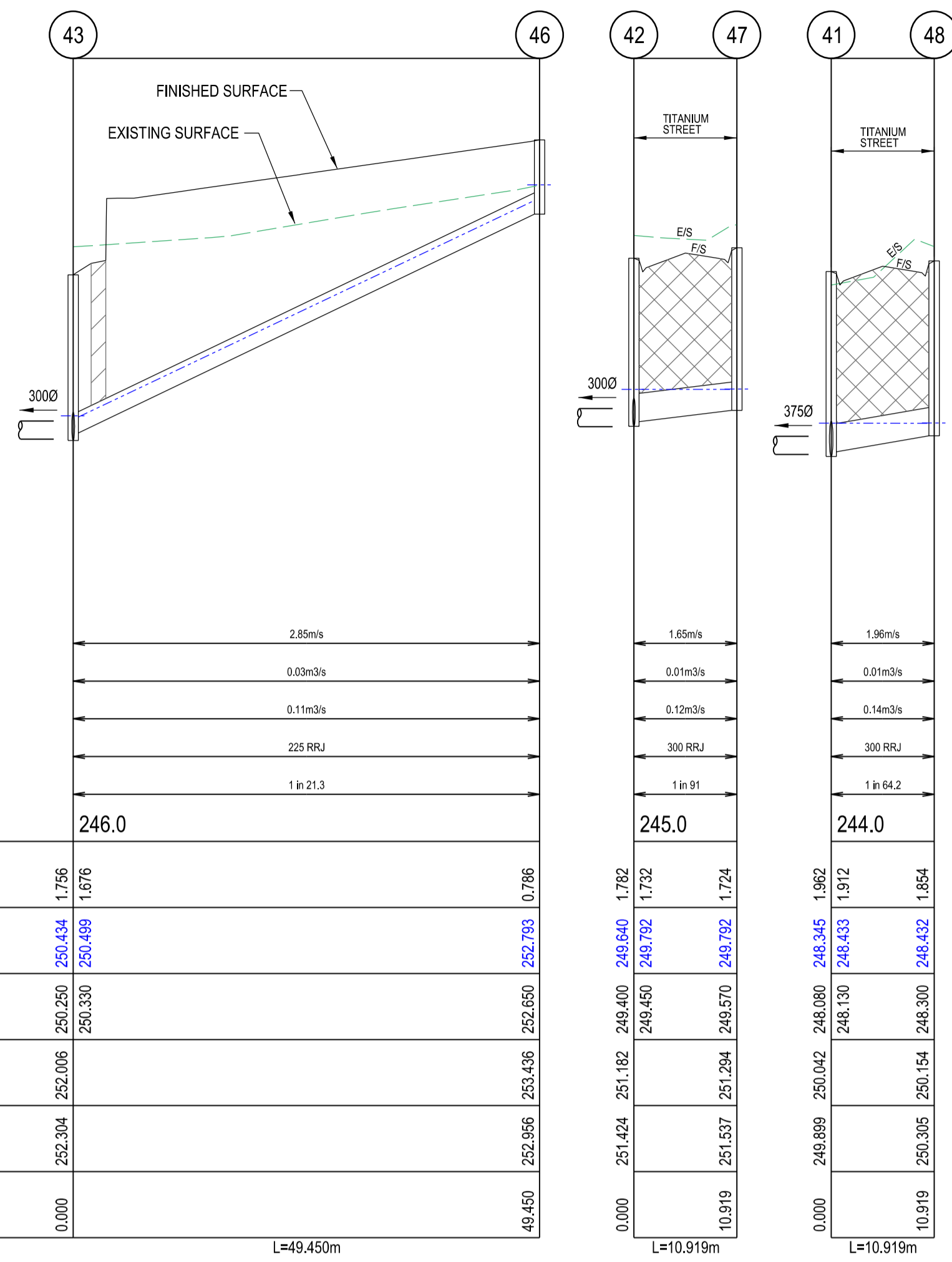

INDICATES CLASS 2 CRUSHED ROCK BACKFILL  
 INDICATES CLASS 3 CRUSHED ROCK BACKFILL  
 INDICATES 5YR HGL

**DRAINAGE LONGITUDINAL SECTIONS**

SCALE HORIZONTAL 1:500  
VERTICAL 1:50

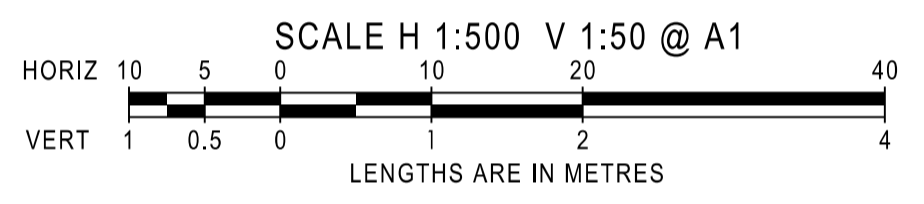

VELOCITY (m/sec)	2.85m/s
DESIGN (m <sup>3</sup> /s)	0.03m <sup>3</sup> /s
CAPACITY (m <sup>3</sup> /s)	0.11m <sup>3</sup> /s
DIAMETER AND TYPE (CLASS 2)	225 RRJ
GRADE	1 in 21.3
DATUM RL	246.0
DEPTH FS TO INVERT	1.796
HGL LEVEL	250.454
INVERT	250.250
FINISHED SURFACE	252.006
NATURAL SURFACE	252.304
CHAINAGE	0.000

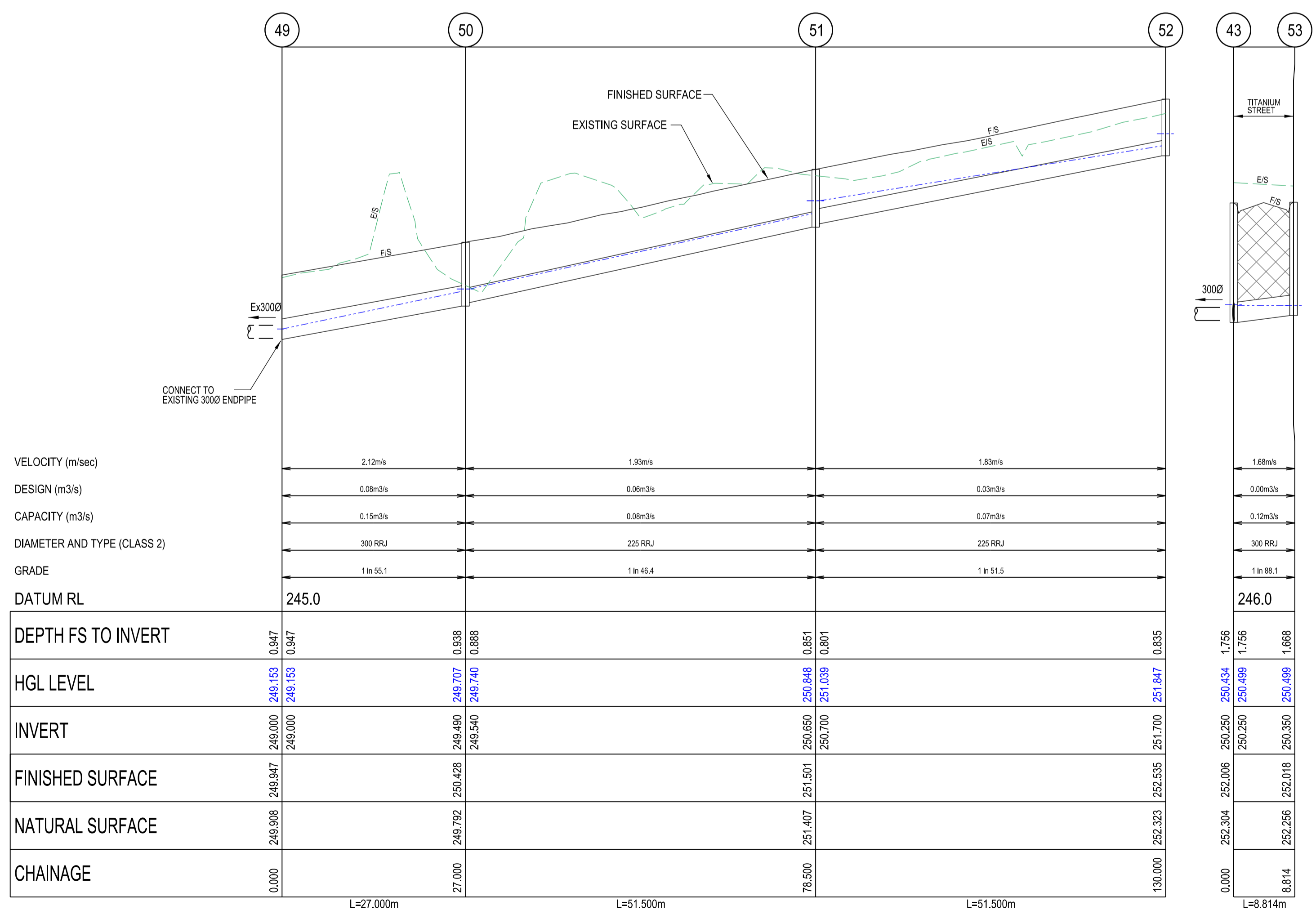

VELOCITY (m/sec)	2.12m/s	1.93m/s	1.83m/s	1.68m/s
DESIGN (m <sup>3</sup> /s)	0.08m <sup>3</sup> /s	0.08m <sup>3</sup> /s	0.03m <sup>3</sup> /s	0.00m <sup>3</sup> /s
CAPACITY (m <sup>3</sup> /s)	0.15m <sup>3</sup> /s	0.08m <sup>3</sup> /s	0.07m <sup>3</sup> /s	0.12m <sup>3</sup> /s
DIAMETER AND TYPE (CLASS 2)	300 RRJ	225 RRJ	225 RRJ	300 RRJ
GRADE	1 in 55.1	1 in 46.4	1 in 51.5	1 in 88.1
DATUM RL	245.0	245.0	246.0	246.0
DEPTH FS TO INVERT	0.947	0.938	0.851	0.835
HGL LEVEL	249.153	249.707	250.848	251.847
INVERT	249.000	249.460	250.650	251.700
FINISHED SURFACE	249.947	250.428	251.501	252.535
NATURAL SURFACE	249.808	249.792	251.407	252.323
CHAINAGE	0.000	27.000	76.500	130.000

STRUCTURE SCHEDULE										
PIT NO.	DESCRIPTION	INTERNAL DIMENSIONS		INLET		OUTLET		TOP OF PIT	DEPTH OF PIT	REMARKS
		L	W	DIA	LEVEL	DIA	LEVEL			
1	Side Entry Pit	900	600	375	247.21			248.99	1.833	Refer Drawing - EDCM 603
2	Side Entry Pit	900	600	375	247.33	375	247.28	249.06	1.780	Refer Drawing - EDCM 603
3	Side Entry Pit	900	600	300	248.40	375	248.35	250.27	1.920	Refer Drawing - EDCM 603
4	Side Entry Pit	900	600	300	248.70	300	248.65	250.43	1.776	Refer Drawing - EDCM 603
5	Side Entry Pit	900	600	300	250.80	300	250.75	252.53	1.778	Refer Drawing - EDCM 603
				300	250.80					
6	Side Entry Pit	900	600	300	253.00	300	252.95	254.81	1.859	Refer Drawing - EDCM 603
7	Side Entry Pit	900	600			300	253.10	254.81	1.707	Refer Drawing - EDCM 603
8	Side Entry Pit	900	600			300	250.90	252.54	1.643	Refer Drawing - EDCM 603
9	Existing Endpipe			300	248.40			249.39	0.988	Connect to Existing 300 Dia Endpipe
10	Junction Pit	900	600	300	248.85	300	248.80	249.89	1.091	Refer Drawing - EDCM 605
11	Junction Pit	900	600	300	250.20	300	249.70	251.13	1.433	Refer Drawing - EDCM 605
12	Junction Pit	900	600	225	251.35	300	250.80	252.26	1.458	Refer Drawing - EDCM 605
13	Junction Pit	900	600	225	252.76	225	252.11	253.59	1.478	Refer Drawing - EDCM 605
14	Junction Pit	900	600			225	253.41	254.31	0.903	Refer Drawing - EDCM 605
15	Existing Endpipe			600	246.91			249.08	2.172	Connect to Existing 600 Dia Endpipe
16	Side Entry Pit	900	900	525	247.19	600	247.14	249.29	2.152	Refer Drawing - EDCM 603 (Provide Haunching as per EDCM 607)
17	Side Entry Pit	900	900	375	248.25	525	248.20	250.23	2.027	Refer Drawing - EDCM 603 (Provide Haunching as per EDCM 607)
				375	248.25					
18	Side Entry Pit	900	600	300	249.95	375	249.90	251.73	1.827	Refer Drawing - EDCM 603 (Provide HD Cover)
				225	250.05					
19	Junction Pit	900	600	300	250.65	300	250.60	252.44	1.841	Refer Drawing - EDCM 605
				300	250.65					
20	Side Entry Pit	900	600	300	251.55	300	251.50	253.43	1.927	Refer Drawing - EDCM 603
21	Junction Pit	900	600	225	252.45	300	252.40	254.12	1.719	Refer Drawing - EDCM 605
22	Junction Pit	900	600	225	253.70	225	253.75	254.86	1.165	Refer Drawing - EDCM 605
23	Junction Pit	900	600			225	254.10	254.50	0.698	Refer Drawing - EDCM 605
24	Side Entry Pit	900	900	300	250.92	300	250.87	252.93	2.064	Refer Drawing - EDCM 603 (Provide Haunching as per EDCM 607)
25	Side Entry Pit	900	600	300	251.05	300	251.00	252.93	1.930	Refer Drawing - EDCM 603
26	Side Entry Pit	900	600	300	251.54	300	251.49	253.28	1.789	Refer Drawing - EDCM 603
27	Endpipe					300	251.85	253.65	1.798	Blank End With Timber
28	Junction Pit	900	600			225	251.75	252.56	0.813	Refer Drawing - EDCM 605
29	Side Entry Pit	900	600	375	248.50	375	248.45	250.32	1.873	Refer Drawing - EDCM 603
30	Side Entry Pit	900	600	375	249.45	375	249.40	251.20	1.797	Refer Drawing - EDCM 603
31	Side Entry Pit	900	600	375	250.45	375	250.40	252.21	1.810	Refer Drawing - EDCM 603
32	Side Entry Pit	900	600	225	252.40	375	252.35	254.12	1.766	Refer Drawing - EDCM 603
33	Junction Pit	900	600			225	254.75	255.55	0.796	Refer Drawing - EDCM 605
34	Existing Endpipe			375	247.36			249.08	1.721	Connect to Existing 375 Dia Endpipe
35	Side Entry Pit	900	600			375	247.64	249.39	1.748	Refer Drawing - EDCM 603
36	Existing Endpipe			300	248.37			249.31	0.941	Connect to Existing 300 Dia Endpipe
37	Junction Pit	900	600	225	248.65	300	248.60	249.59	0.990	Refer Drawing - EDCM 605
38	Junction Pit	900	600	225	249.95	225	249.90	250.87	0.971	Refer Drawing - EDCM 605
39	Junction Pit	900	600			225	251.10	252.16	1.059	Refer Drawing - EDCM 605
40	Existing Endpipe			375	247.22			249.16	1.942	Connect to Existing 375 Dia Endpipe
41	Side Entry Pit	900	600	300	248.13	375	248.08	250.04	1.962	Refer Drawing - EDCM 603
				300	248.13					
42	Side Entry Pit	900	600	300	249.45	300	249.40	251.18	1.782	Refer Drawing - EDCM 603
				300	249.45					
43	Junction Pit	900	600	300	250.30	300	250.25	252.01	1.756	Refer Drawing - EDCM 605
				225	250.33					
44	Junction Pit	900	600	300	251.10	300	251.05	252.79	1.743	Refer Drawing - EDCM 605
45	Side Entry Pit	900	600			300	251.55	253.31	1.763	Refer Drawing - EDCM 603
46	Junction Pit	900	600			225	252.65	253.44	0.786	Refer Drawing - EDCM 605
47	Side Entry Pit	0	0			300	249.57	251.29	1.724	Refer Drawing - EDCM 603
48	Side Entry Pit	0	0			300	248.30	250.15	1.854	Refer Drawing - EDCM 603
49	Existing Endpipe			300	249.00			249.95	0.947	Connect to Existing 300 Dia Endpipe
50	Junction Pit	900	600	225	249.54	300	249.49	250.43	0.938	Refer Drawing - EDCM 605
51	Junction Pit	900	600	225	250.70	225	250.65	251.50	0.851	Refer Drawing - EDCM 605
52	Junction Pit	900	600			225	251.70	252.54	0.835	Refer Drawing - EDCM 605
53	Junction Pit	900	600			300	250.35	252.02	1.668	Refer Drawing - EDCM 605 (Provide HD Cover)

AMENDMENTS				 breese pitt dixon pty. ltd. land surveyors civil engineers	1/19 cato street hawthorn east, 3123 telephone 8823 2300 fax no. 8823 2310
				MELWAY REF. 367-F-3 SURVEY VERIS DESIGN R.W. DRAWN D.W.	MUNICIPALITY <b>HUME</b> REFERENCE 8460 E/328
				<b>CLOVERTON ESTATE</b> <b>STAGE 328</b> <b>DRAINAGE LONG SECTIONS</b>	DATE AUG '22 SHEET 13 OF 16 P1



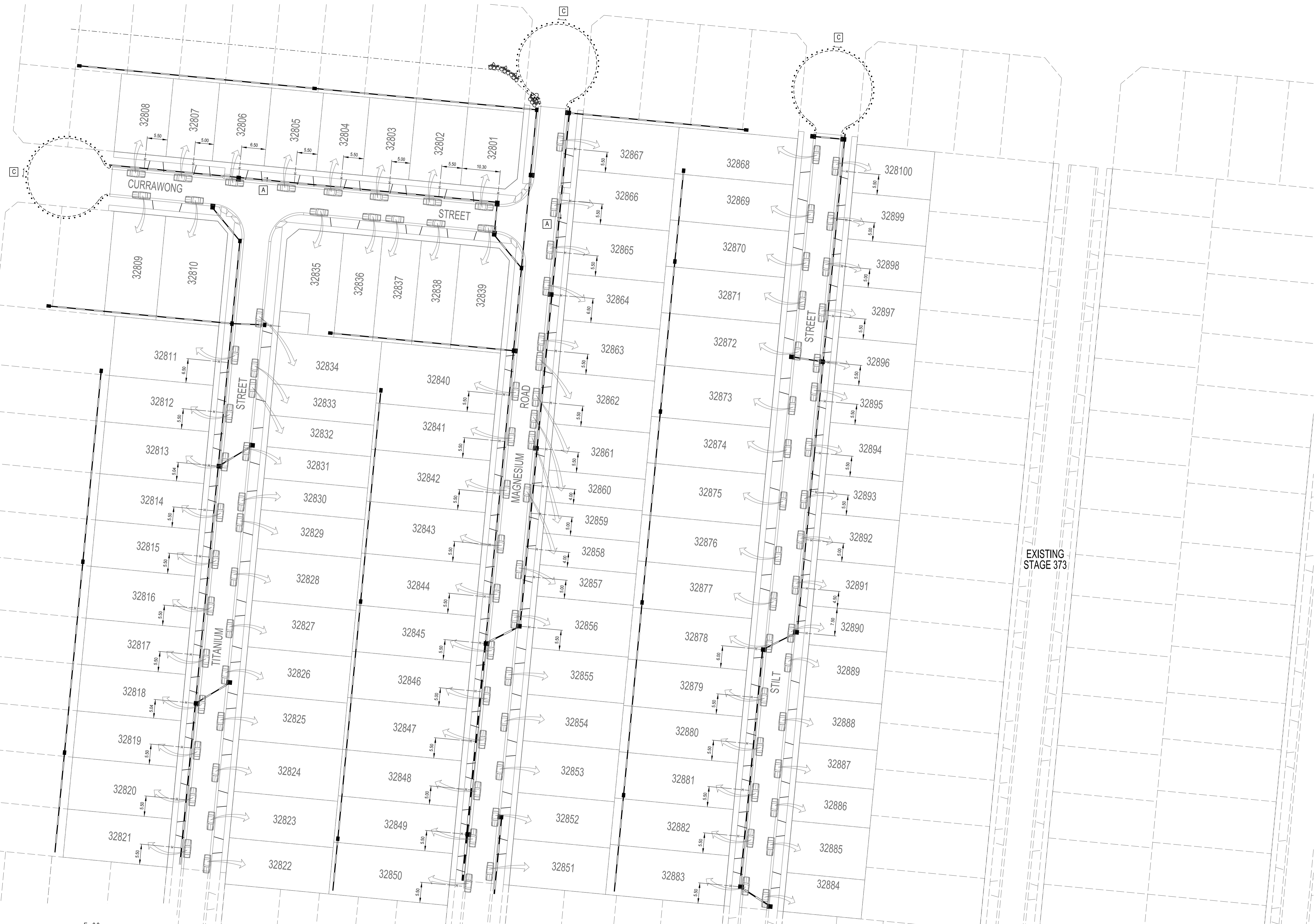
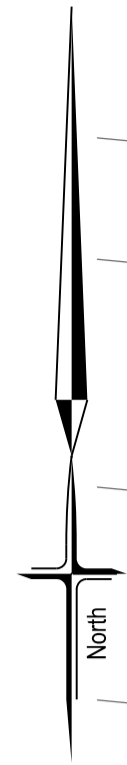

**SIGNAGE LEGEND**

<b>A</b>	STREET SIGNS
<b>B</b>	GIVE WAY (R1-2)
<b>C</b>	ROAD CLOSED SIGN (G9-20) WITH OBSTRUCTION MARKER SIGN (D4-5) - CLASS 1

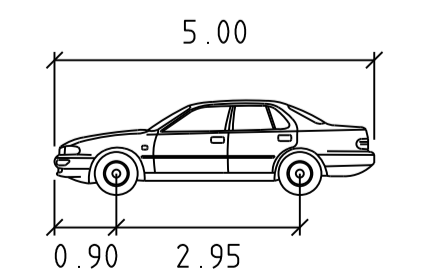

**NOTES**

a) ALL SIGNS TO BE SLEEVED USING A SL27 SLEEVE.

b) SWLM - INDICATES SOLID WHITE 'LONGLIFE' LINE MARKING  
 BWLM - INDICATES BROKEN WHITE 'LONGLIFE' LINE MARKING

**CAR** meters

Width : 1.90  
 Track : 1.55  
 Lock to Lock Time : 6.00  
 Steering Angle : 33.00



AMENDMENTS	VER	DATE	REMARKS

<p>land surveyors civil engineers</p>	MELWAY REF. 386-F-3	<p><b>COLVERTON ESTATE</b>  <b>STAGE 328</b>  <b>SIGNAGE &amp; LINEMARKING PLAN</b></p>	MUNICIPALITY <b>HUME</b>
	SURVEY VERIS		REFERENCE 8460E/328
	DESIGN R.W.		
	DRAWN D.W.		
CHECKED A.K.	SCALE AS SHOWN	DATUM AHD	DATE FEB '22
			SHEET 14 OF 16
			P1

1/19 cato street  
 hawthorn east, 3123  
 telephone 8823 2300  
 fax no. 8823 2310



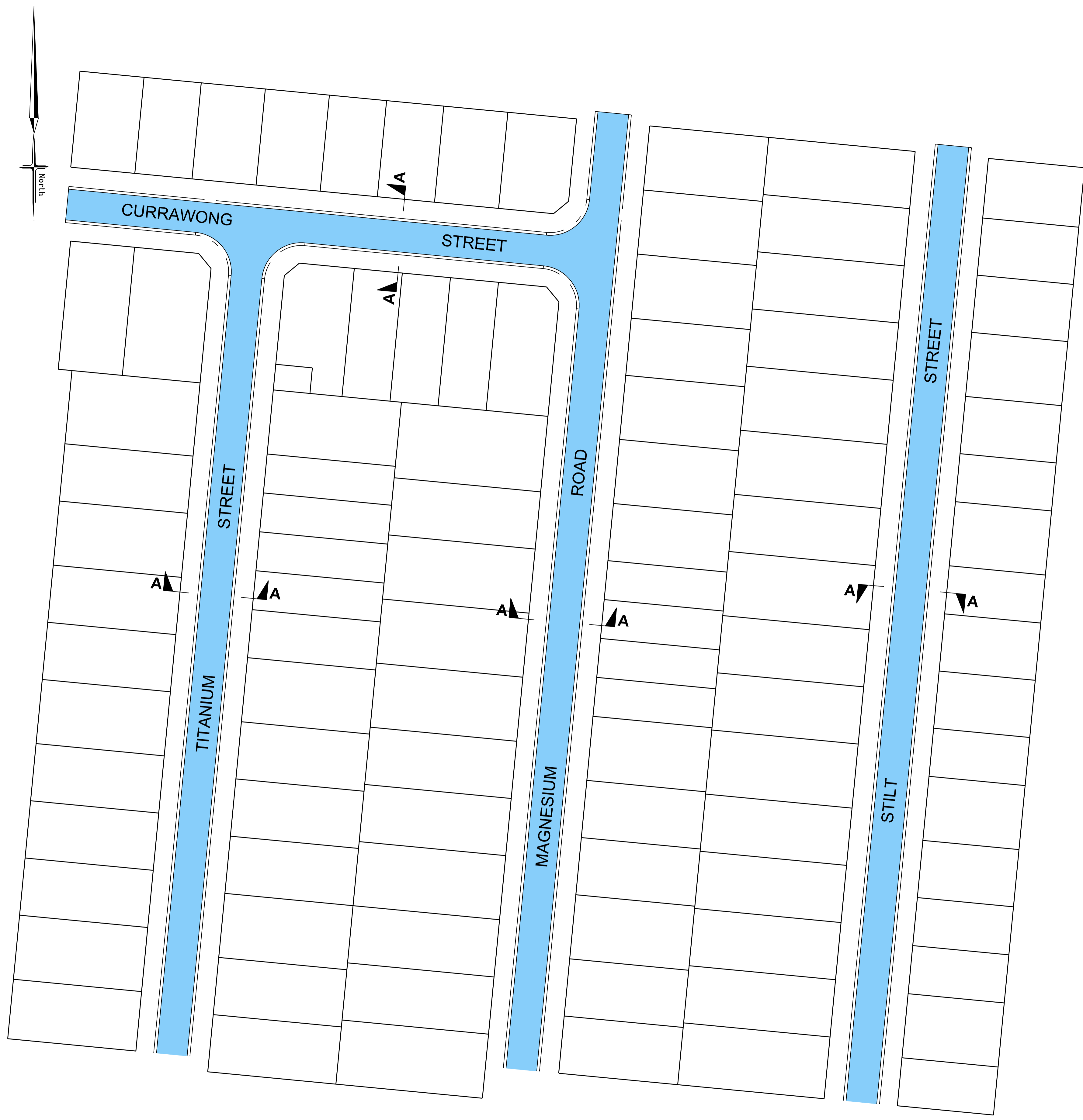

PLAN  
NTS

LEGEND  
 670mm PAVEMENT (REFER DETAILS)

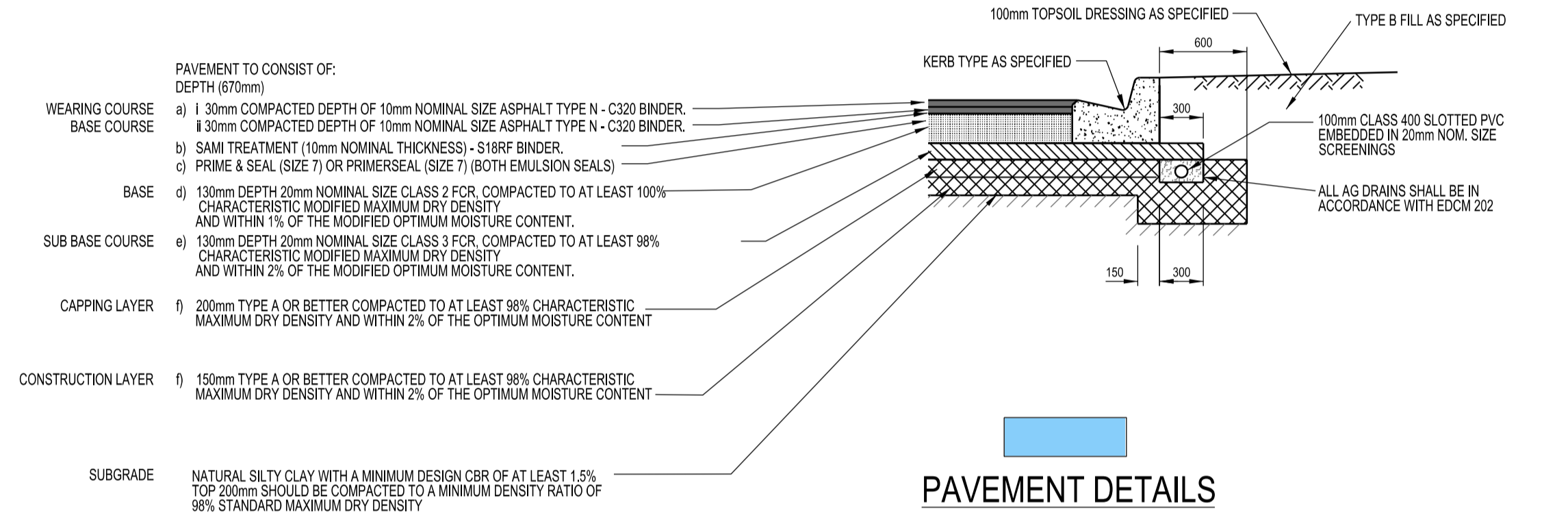

PAVEMENT DETAILS  
 TITANIUM STREET, CURRAWONG STREET, MAGNESIUM ROAD & STILT STREET

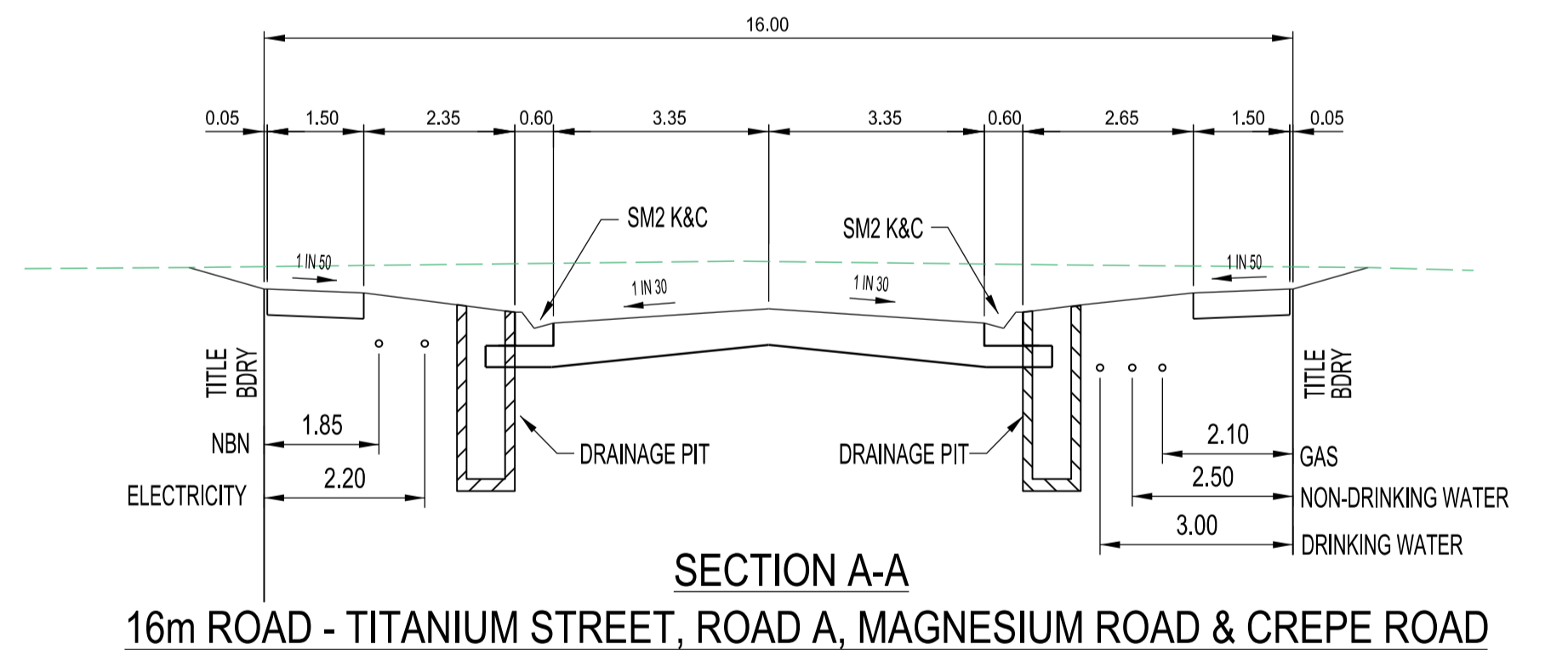

AMENDMENTS		 breese pitt dixon pty. ltd. land surveyors civil engineers		1/19 cato street hawthorn east, 3123 telephone 8823 2300 fax no. 8823 2310	
		MELWAY REF. 386-F-3 SURVEY VERIS DESIGN R.W. DRAWN D.W.		MUNICIPALITY <b>HUME</b> REFERENCE 8460 <sup>E</sup> /328	
		<b>CLOVERTON ESTATE          STAGE 328          TYPICAL CROSS SECTIONS</b>		SHEET 15 OF 16 P1	
VER	DATE	REMARKS	CHECKED A.K.	SCALE AS SHOWN	DATUM AHD
					DATE AUG'22

E:\Engineering\Breese Pitt Dixon\Cloverton\Stage 328\Cadd\128.R15.TC.dgn



**MASS ROCK RETAINING WALL SCHEDULE**

MAX WALL HEIGHT - H (mm)	FOUNDING DEPTH - D (mm)	BASE WIDTH - B (mm)	FRONT FACE SETBACK - S (mm)	CREST WIDTH - C (mm)
400	300	450	15	300
500	300	500	15	300
600	300	500	30	300
800	300	550	30	300
1000	300	600	30	300

**RETAINING WALL NOTE R.1.**

a. WHERE FOOTPATH ABUTS RETAINING WALL CONTINUE CONCRETE UP TO BASE OF RETAINING WALL

**FOOTING NOTE F.2.**

- a. TOE OF WALL SHALL PENETRATE THROUGH ANY FILL MATERIAL & THE NATURAL SILT SOILS TO BE FOUNDED AT LEAST 100mm INTO THIS UNDERLYING NATURAL STIFF CLAY OR WEATHERED ROCK. ALL EXCAVATIONS SHALL HAVE FOUNDED DEPTHS AND BEARING CAPACITY APPROVED BY THE ENGINEER OR BUILDING SURVEYOR BEFORE CONCRETE IS PLACED. FOOTING EXCAVATIONS WHICH ARE DEEPEMED TO PENETRATE THROUGH UNSUITABLE SOILS SHALL BE BACKFILLED UP TO UNDERSIDE OF FOOTINGS WITH 15 MPa BLINDING CONCRETE.
- b. ALL EXCAVATION FOUNDED SURFACES SHALL BE LEVEL ( NOT INCLINED) CLEAN CUT & FREE OF MUD OR WATER.
- c. ALL SEEPAGE INFLOW SHALL BE REMOVED BEFORE PLACEMENT OF CONCRETE.
- d. FOOTINGS SHALL BE FOUNDED IN STIFF NATURAL CLAY HAVING A SAFE BEARING CAPACITY OF 100KPa.
- e. WHERE A PARALLEL SEWER IS PROPOSED ADJACENT TO THE RETAINING WALL, LOWER FOUNDED DEPTH 'D' TO ENSURE SEWER PIPE IS ABOVE THE 45° ANGLE OF REPOSE.

RETAINING WALL DETAILS ARE NOT PART OF THE SUB DIVISIONAL WORKS OR APPROVAL AND IS SUBJECT TO SEPARATE APPROVAL.

THIS SHEET IS SUPPLEMENTARY TO THE ENGINEERING PLANS.

CONCRETE SLEEPER RETAINING WALL DIMENSIONS		
MAX WALL HEIGHT - H (mm)	FOUNDING DEPTH - D (mm)	GALV. SOLDIER SIZE
400	600	150 UB 14
600	900	150 UB 14
800	1200	150 UB 14
1000	1500	150 UB 14

- NOTES:**
- ALL STEELWORK IS TO BE HOT DIPPED GALVANISED.
  - IF BEDROCK OR BASALT BOULDER IS STRUCK DURING PIER DRILLING PROVIDE 600 MIN SOCKET.
  - ALL SOLDIERS TO BE FOUNDED AT DEPTH 'D' OR 1000mm BELOW THE INVERT OF THE ADJACENT EXISTING SEWER, WHICHEVER IS THE GREATER.
  - WHERE A PARALLEL SEWER IS PROPOSED ADJACENT TO THE RETAINING WALL, PIER DEPTH 'D' IS TO BE EXTENDED 1.0m MIN BELOW SEWER PIPE. REFER SEWER LS FOR DEPTH.

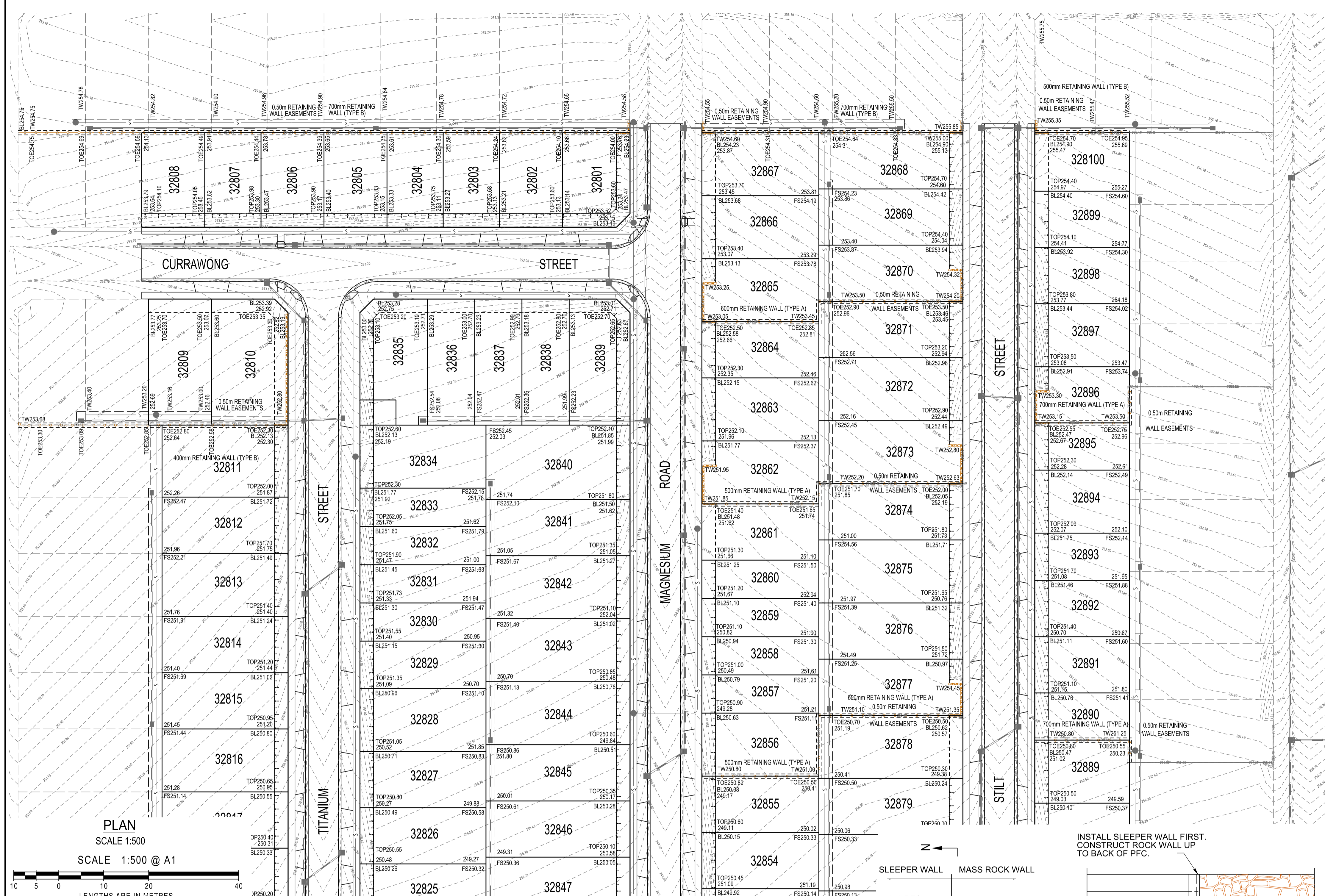

PLAN  
SCALE 1:500  
SCALE 1:500 @ A1  
LENGTHS ARE IN METRES

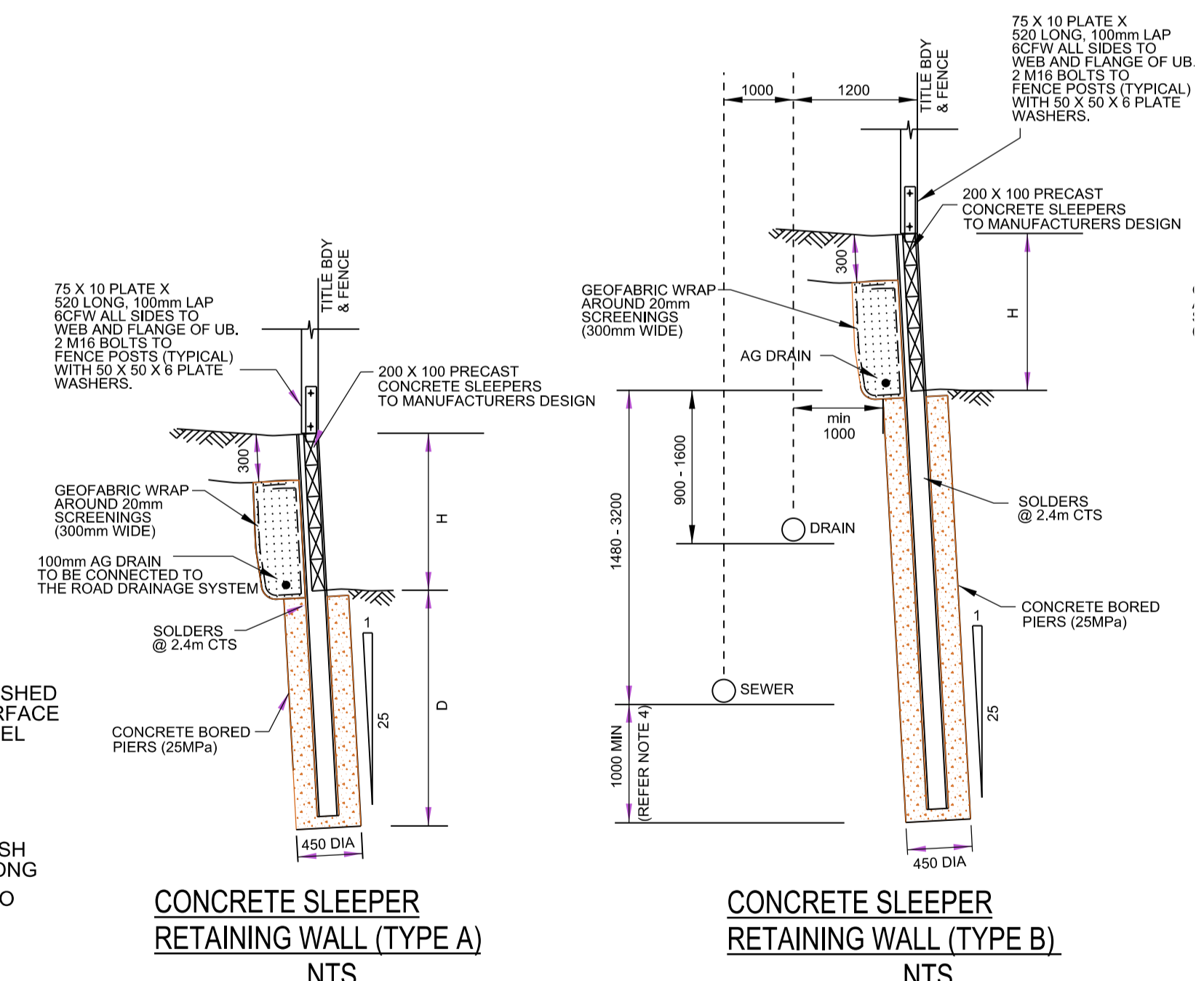
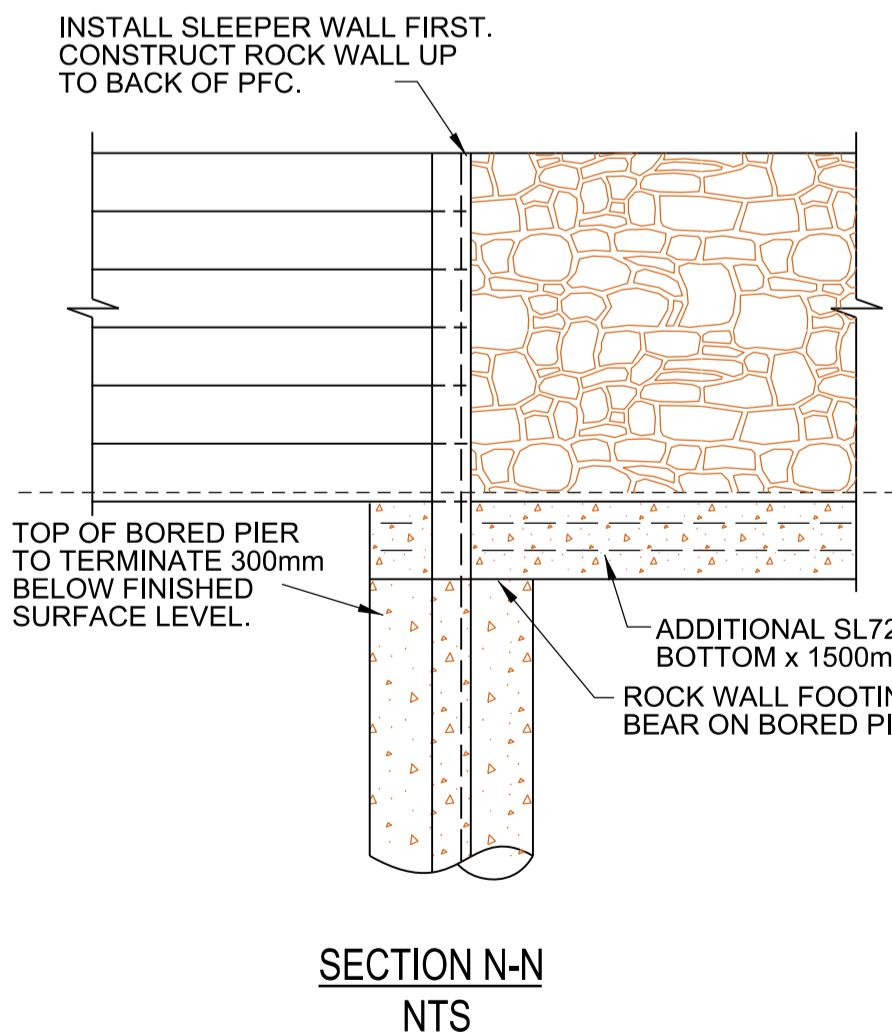
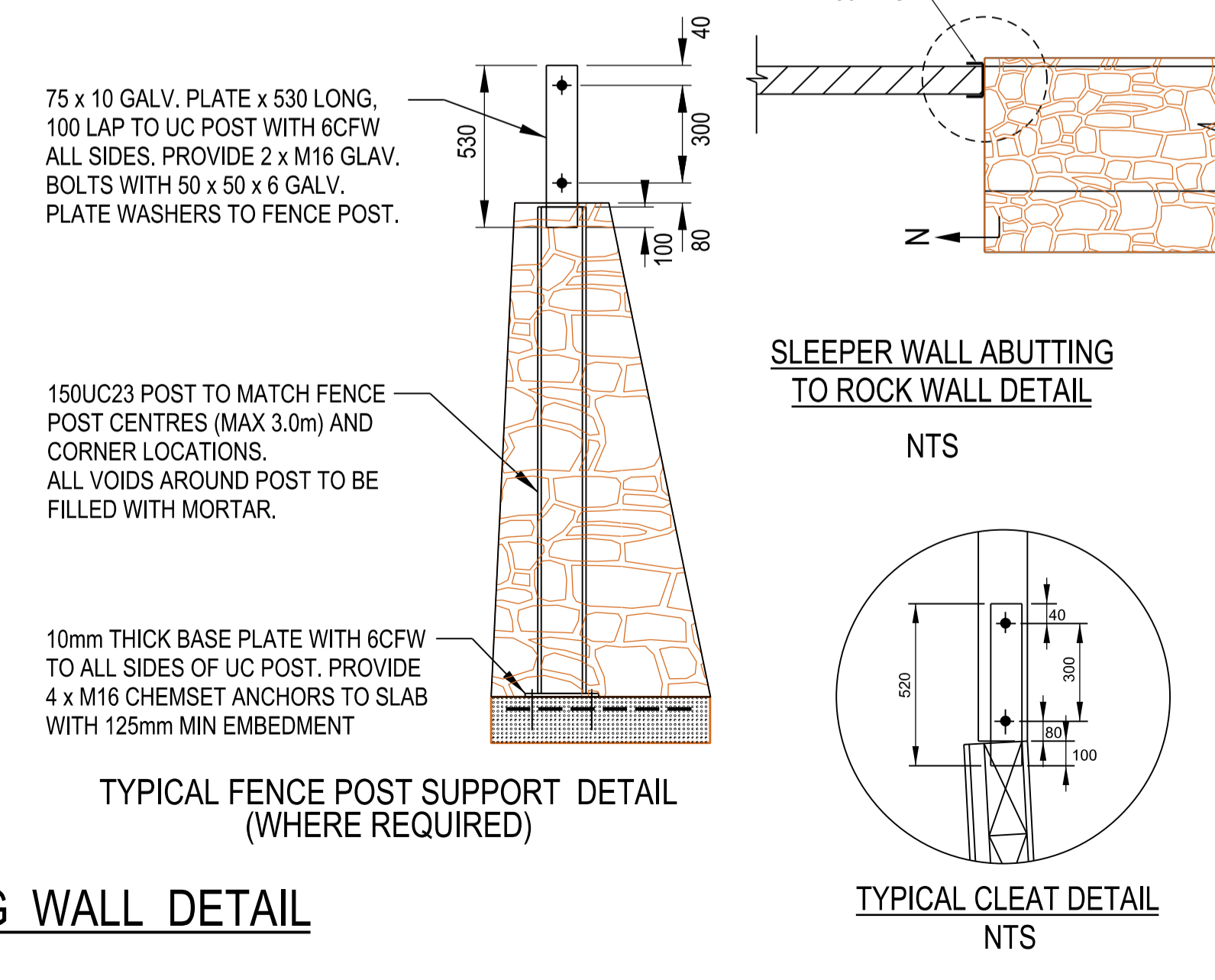
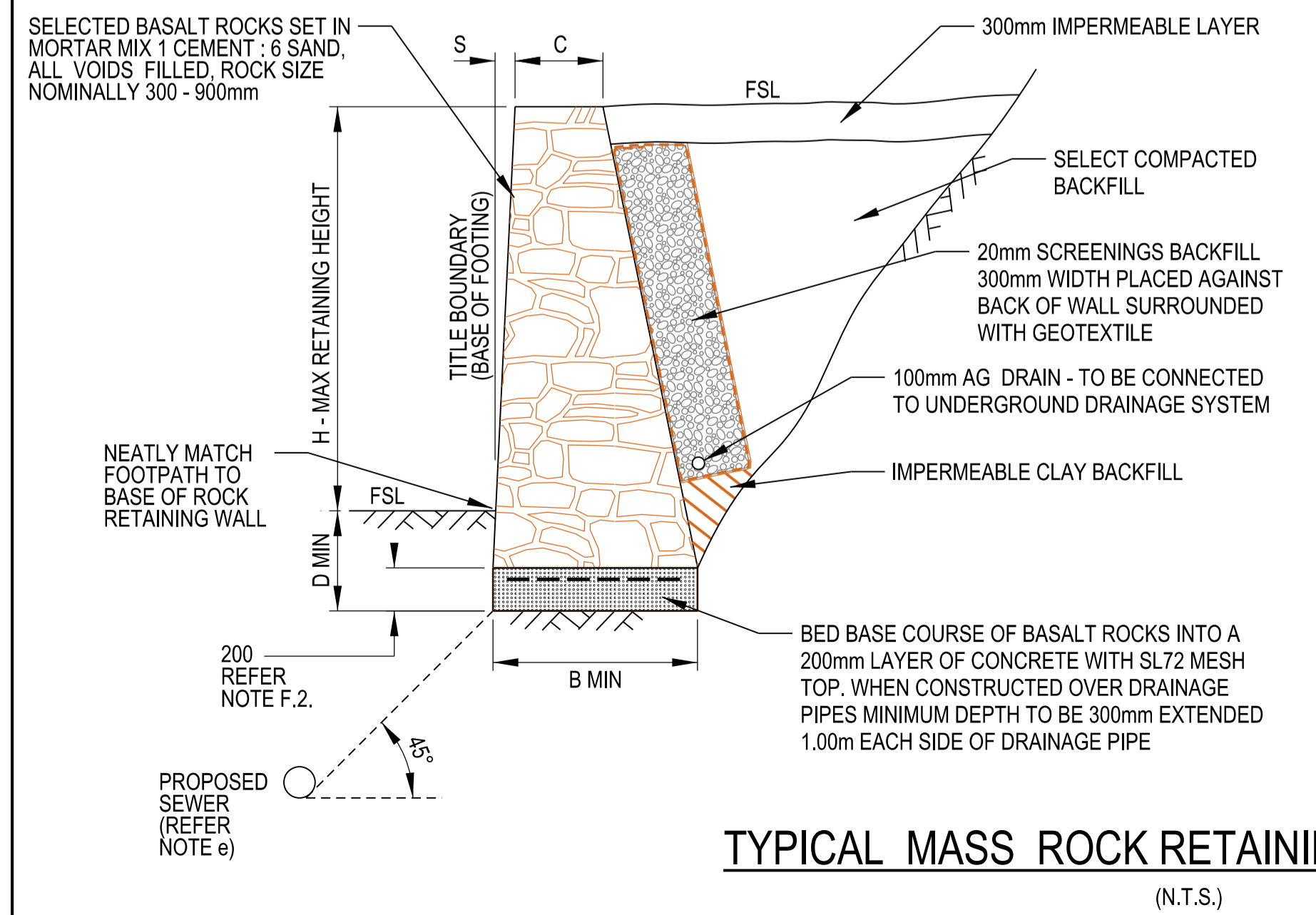

AMENDMENTS	DATE	REMARKS	CHECKED	SCALE	DATUM	AHD	DATE	SHEET
			A.K.	AS SHOWN			AUG 22	16 OF 16

**breese pitt dixon pty. ltd.**  
land surveyors civil engineers

**CLOVERTON ESTATE**  
**STAGE 328**  
**RETAINING WALL PLAN & DETAILS**

1/19 cato street  
hawthorn east, 3123  
telephone 8823 2300  
fax no. 8823 2310

MUNICIPALITY  
**HUME**  
REFERENCE  
8460 E/328







# The Inclusions

---

## Pre-Construction

Fixed site costs

Provide 7 Star Energy Efficiency

Termite Treatment (if applicable)

Mains Power Connection

Sewerage and Stormwater Connection

Water Connection

---

## External Inclusions

Sectional Garage Door

Concrete Roof Tiles

Colorbond Fascia, Gutter and Downpipes

Clay Brickwork Cladding

Fibre Cement Sheet Infills over Windows and Doors

Sustainability Victoria approved hot water unit

---

## Internal Inclusions

2550mm high ceiling height

Carpet to Bedrooms and Robes

Ceramic wall tiles to Bathroom and Ensuite

Ceramic floor tiles to wet areas including tiled skirt

Ceramic wall tiles to Kitchen and Laundry

Laminate timberlook floating floor system to Kitchen and Living areas

Blockout roller blinds to windows

Ducted Heating to Bedrooms and Living areas

Ducted Evaporative Cooling

Double power points throughout

Television and Telephone/Data points (refer to plan for locations)

LED downlights throughout (excludes Garage)

---

## Kitchen Inclusions

Stainless Steel 900mm upright cooker, gas cooktop and rangehood

Stainless steel dishwasher

---

20mm reconstituted stone benchtop with 40mm polished edge to Kitchen

Chrome mixer tap

---

## Bathroom/Ensuite/WC Inclusions

20mm reconstituted stone benchtop with 20mm polished edge to vanities

Acrylic bath tub

Chrome mixer tap to basins

Tiled showerbases

---

## Turn Key

Clothesline

Letterbox

Television antenna

Landscaping to front and rear yard, including turf, topping to pathways and mulched garden beds with plants (site specific)

Exposed aggregate concrete to driveway, path and porch

Side and rear boundary fences to building line as required

Developer Guidelines

Building permit

---

## Post Construction

3 months maintenance period

Home owners warranty in accordance with Victorian regulations

Internal and external builder's house clean

Appliance manuals / compliance certificates

---